

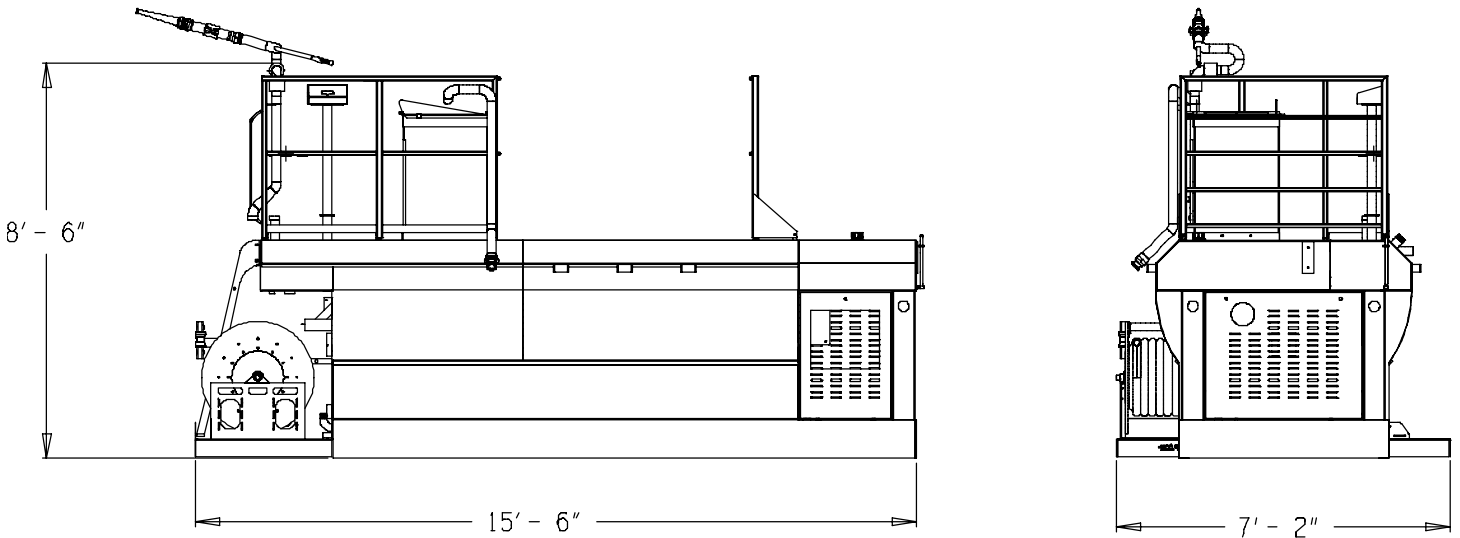

Pik Rite Inc.  
 60 Pik Rite Lane  
 Lewisburg, PA 17837  
 800-326-9763  
 www.edenequip.com



## ***1200 Gal. Skid Unit SPECIFICATIONS***

Engine HP	48 HP Kubota Diesel
Tank Capacity	1,308 Gal.
Tank Working Capacity	1,200 Gal.
Pump	3" inlet x 2" outlet Centrifugal
Pump Drive System	Hydraulic w/ Remote Control
Agitation	Mechanical
Agitation Drive System	Hydraulic w/ Reverse & Speed Control
Hose Reel	Electric rewind w/ Remote Control
Hose	145' of 1 1/4" w/ Full Flow Fittings
Turret Gun	2"
Nozzles	50° & 80°
Weight of unit (Empty)*	5700 lbs.
Weight of unit (Full)*	15,540 lbs.

\*Weights are approximate and do not include materials being stored on the unit.

\*\*Pik Rite Inc. reserves the right to change design specification without notice.