



PARTS CATALOG

HYDRA-RAM 1190 MANURE SPREADER



Pik Rite, Inc
60 Pik Rite Lane
Lewisburg, PA 17837
Ph. 800-326-9763
Fx. 570-523-8175
www.pikrite.com

January 2014





HYDRA-RAM 1190 MANURE SPREADER

(SPECIFICATIONS AND DESIGN SUBJECT TO CHANGE WITHOUT NOTICE)

DIRECTION ARROW

ARROWS ARE USED WITH ILLUSTRATIONS TO INDICATE THE FRONT OF THE UNIT. "RIGHT-HAND" AND "LEFT-HAND" SIDES ARE DETERMINED BY FACING THE DIRECTION OF MACHINE FORWARD TRAVEL.

BOX ENCLOSED ILLUSTRATIONS

A REFERENCE NUMBER, SHOWN IN THE PARTS LIST, IS ASSIGNED TO A BOX ENCOMPASSING ALL PARTS SOLD AS A SERVICE ASSEMBLY.

REFERENCE NUMBER IDENTIFICATION

000-099 PARTS USED FOR ASSEMBLY
100-199 BOLTS & FASTENERS
800-899 REPLACEMENT PARTS OR SERVICE ASSEMBLIES –
USED TO REPLACE OR REBUILD COMPONENTS OF THE
MACHINE

TABLE OF CONTENTS

7103-1-1	Main Frame & Side Panels	8
7103-1-2	Main Floor & Guides for Sliding Floor	10
7103-1-3	Sliding Floor.....	12
7103-1-4	Moving Panel.....	14
7103-1-5	Front Panel & Shields	16
7103-1-6	Beater Support Panels.....	18
7103-1-6A	Beater Support Panels, S.N.'s 71003001-71004018.....	20
7103-1-7	Endgate	22
7103-1-8	Front Splash Guard	24
7103-1-9	End Pan.....	26
7103-1-10	Walking Beam.....	28
7103-1-10A	Walking Beam, S.N.'s 71003001-71004020.....	30
7103-1-11	Hubs & Spindle, Tires & Wheels, Implement	32
7103-1-12	Hubs & Spindles, Tires & Wheels, Truck	34
7103-1-13	Optional Endgate Debris Belting, Standard Upper Beater	36
7103-2-1	1000 rpm Constant Velocity Driveline w/ Clutch	38
7103-2-1A	1000 RPM Con. Vel. Shaft w/Clutch, S.N. 71007009-.....	42
7103-2-2	Friction Clutch.....	46
7103-2-4	Front Input Shaft, Sprockets & Chain	48
7103-2-5	Side Drive Shaft & Shields.....	50
7103-2-6	Gear Case	52
7103-2-7	Main Beater	54
7103-2-8	Interm. Beater	56
7103-2-8A	Interm. Beater, S.N.'s 71003001-71004018	58

7103-2-9 Interm. Beater Drive - Sprockets & Chain.....60

7103-2-9A Interm. Beater Drive, S.N.'s 71003001-71004018.....62

7103-2-10 Upper Beater64

7103-2-11 Upper Beater Drive - Sprockets & Chain66

7103-3-1 Hydraulics, Main68

7103-3-2 Hydraulics, Endgate.....70

7103-3-3 Main Cylinder.....72

7103-3-4 Secondary Cylinder74

7103-3-5 Endgate Cylinder76

7103-3-6 Optional Control Valve, Closed Center Hydraulic System78

7103-3-7 Optional Control Valve, Open Center Hydraulic System.....80

7103-4-2 Safety Tow Chain82

7103-4-3 Jack Stand.....84

7103-4-4 SMV Emblem & Brackets86

7103-4-5 Decals on Front of Spreader.....88

7103-4-6 Decals on Sides of Spreader90

7103-4-8 Manual Holder92

PARTS
CATALOG

7103-1-1 Main Frame & Side Panels

<u>Ref</u>	<u>Part No.</u>	<u>Description</u>	<u>Parts – Assembly</u>	<u>Will Fit SN</u>	<u>Remarks</u>
1	PR22472	Frame Weldment, 1190 Spreader	1		
2	PR44542	Panel, Side, 1190 Spreader	2		
3	PR38365	Angle, Sliding Floor	2		
4	PR39185	Bumper Rail, Top Rail Protector	2		
5	PR30289	Cylinder Pin	1		
6	PR58806	Retaining Ring, 63/64' (.984) Shaft Size, External	2		
7	PR22488	Steel Board, Spreader Spacer	2		
8	PR5057	Shield, Side Board Cover, 1190 Spreader	2		
101	BL-6-125-C	3/8 UNC X 1 1/4 CARRIAGE BOLT GR5 ZINC	20		
102	BL-6-150-C	3/8 UNC X 1 1/2 CARRIAGE BOLT GR5 ZINC	34		
103	BL-6-175-C	3/8 UNC X 1 3/4 CARRIAGE BOLT GR5 ZINC	30		
104	BL-6-250-H	3/8-16 X 2 1/2 HH C/S GR5 ZC	6		
105	BL-6-300-H	3/8 UNC X 3 HH C/S BOLT GR5 ZINC	3		
106	BL-6-350-H	3/8-16 X 3 1/2 HEX CAP G5 ZC	2		
107	BL-6-400-H	3/8-16 X 4 HEX CAP G5 ZC	1		
108	BL-6-N	3/8-16 HEX NUTS ZC	84		
109	BL-6-LW	3/8 SPLIT LW ZC	84		
110	BL-6-SW	3/8 SAE FW ZC	30		
111	BL-6-FW	3/8 USS FW ZC	66		
112	BL-6-LN	3/8 UNC FIN HEX LOCK NUT NE A563 GrA ZINC	12		
113	BL-6-FFW	3/8 Finish Fender Washer, 2' OD, ZC	8		

7103-1-1 MAIN FRAME & SIDE PANELS

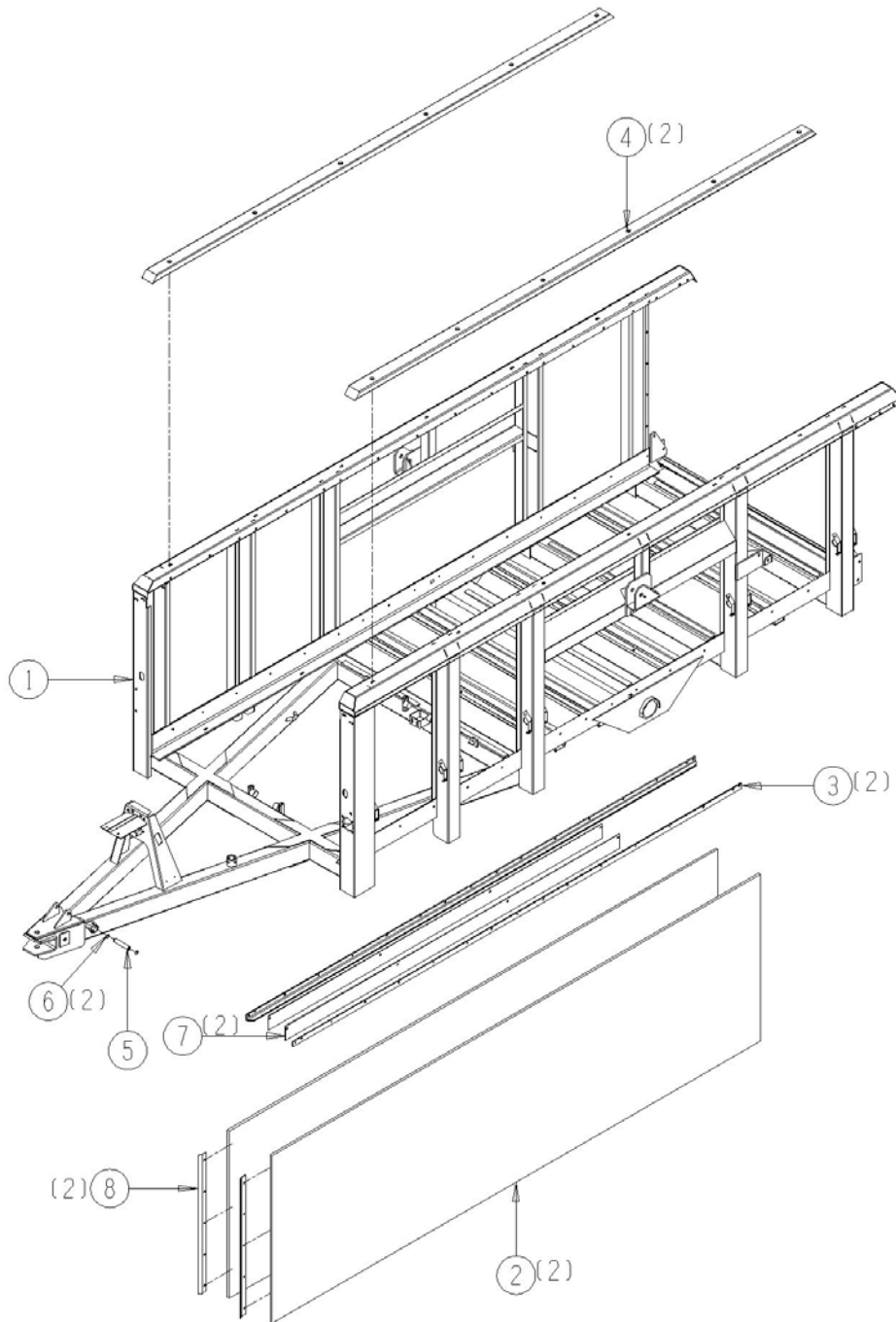

7103-1-2 Main Floor & Guides for Sliding Floor

<u>Ref</u>	<u>Part No.</u>	<u>Description</u>	<u>Parts – Assembly</u>	<u>Will Fit SN</u>	<u>Remarks</u>
1	PR33358	Slide, Wood, Front, Spreader	2		
2	PR33279	Panel, Main Floor, Spreader, 790,1190	1		
3	PR22499	Wear Plate	2		
4	PIN-C4-32	Cotter Pin .25 x 2"	2		
5	PR33555	Angle	1		
6	PR32639	Support, Cylinder, UHMW	1		
7	PR22495	Floor Retainer, 1190, 2-Piece Floor	1		
101	BL-6-150-H	3/8-16 X 1 1/2 HEX CAP G5 ZC	4		
102	BL-6-125-C	3/8 UNC X 1 1/4 CARRIAGE BOLT GR5 ZINC	2		
103	BL-6-100-H	3/8 UNC X 1 HH C/S BOLT GR5 ZINC	2		
104	BL-6-LN	3/8 UNC FIN HEX LOCK NUT NE A563 GrA ZINC	18		
105	BL-6-FW	3/8 USS FW ZC	20		
106	BL-6-SW	3/8 SAE FW ZC	4		

7103-1-2
MAIN FLOOR & GUIDES FOR SLIDING FLOOR

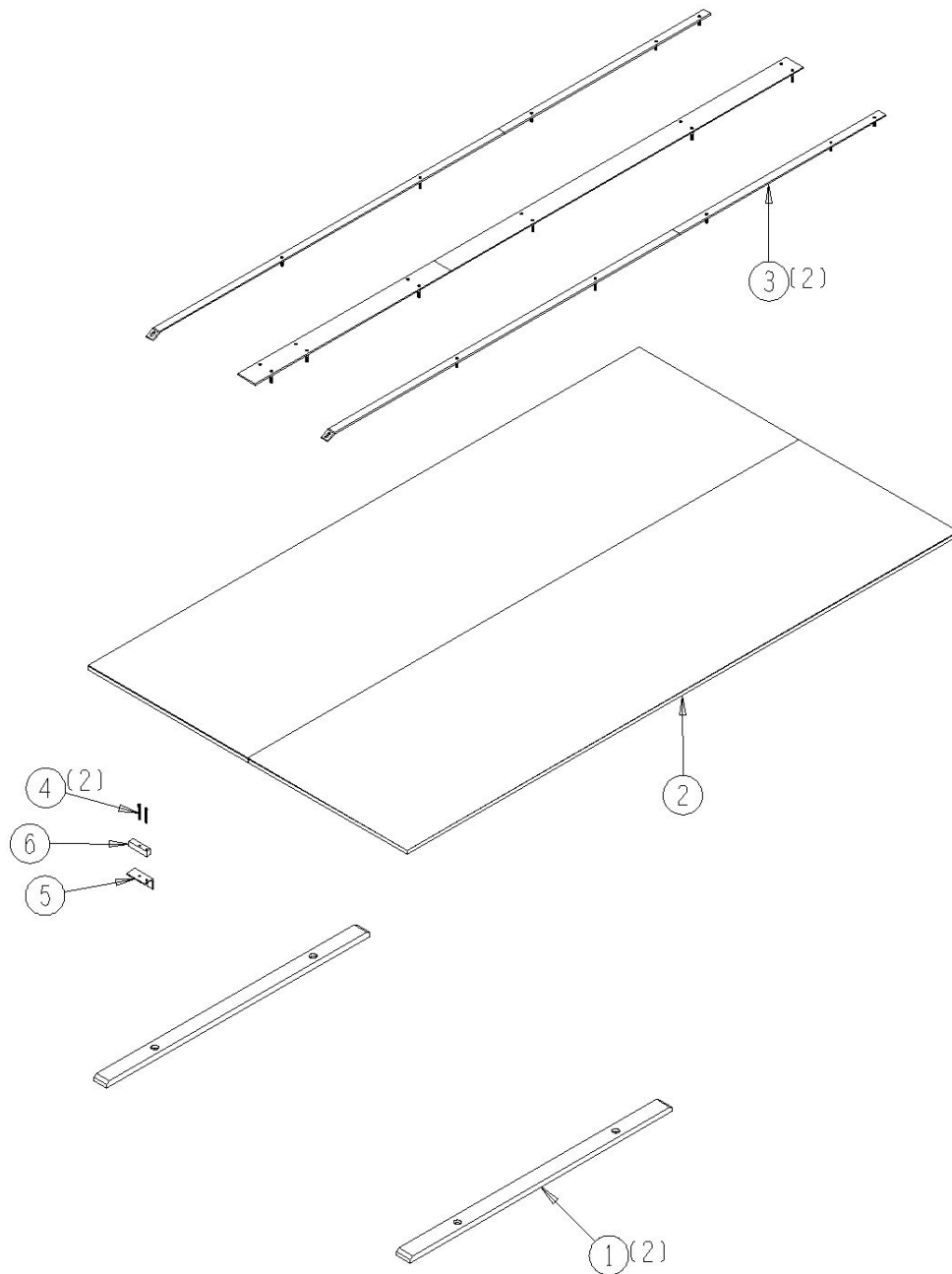

7103-1-3 Sliding Floor

<u>Ref</u>	<u>Part No.</u>	<u>Description</u>	<u>Parts – Assembly</u>	<u>Will Fit SN</u>	<u>Remarks</u>
1	PR23219	Support, Cylinder Mount, Sliding Floor	1		
2	PR25873	Sliding Floor, Inside, Spreader, 790,1190	1		
3	PR30289	Cylinder Pin	1		
4	PR33352	Belting, Bottom Bed Scraper, Sliding Floor	0		
4	PR33353	Flap, Bottom Bed Scraper, Sliding Table, Slurry, Spreader	1		
5	PR33354	Retaining Bar, Sliding Floor, 790,1190	0		
5	PR33355	Bottom Bed Scraper, Sliding Floor, Slurry, Spreader	1		
6	PR38758	Plastic Guide, Hydraulic Cylinder, Sliding Floor	1		
7	PR38760	Plug, Sliding Floor, Spreader	1		
8	PR44533	Panel, Sliding Floor, Spreader 790,1190	1		
9	PR58806	Retaining Ring, 63/64" (.984) Shaft Size, External	2		
101	BL-10-LW	5/8 SPLIT LW ZC	1		
103	BL-8-200-35H8	0.8 x 16mm-2.0 x 35 Gr 8 HH Bolt Zinc Coated	1		
104	BL-6-350-C	3/8 UNC X 3 1/2 CARRIAGE BOLT GR5 ZINC	2		
105	BL-5-125-H	5/16-18 X 1 1/4 HEX CAP G5 ZC	8		
106	BL-10-150-H	5/8-11 X 1 1/2 HEX CAP G5 ZC	4		
107	BL-5-075-H	5/16-18 X 3/4 HEX CAP G5 ZC	2		
108	BL-6-SW	3/8 SAE FW ZC	2		
109	BL-10-LN	5/8-11 HEX LN NE ZC	4		
110	BL-10-SW	5/8 SAE FW ZC @	9		
111	BL-5-FW	5/16 USS FW ZC	10		
112	BL-5-LW	5/16 SPLIT LW ZC	10		
113	BL-6-N	3/8-16 HEX NUTS ZC	2		
114	BL-6-LW	3/8 SPLIT LW ZC	2		

7103-1-3
SLIDING FLOOR

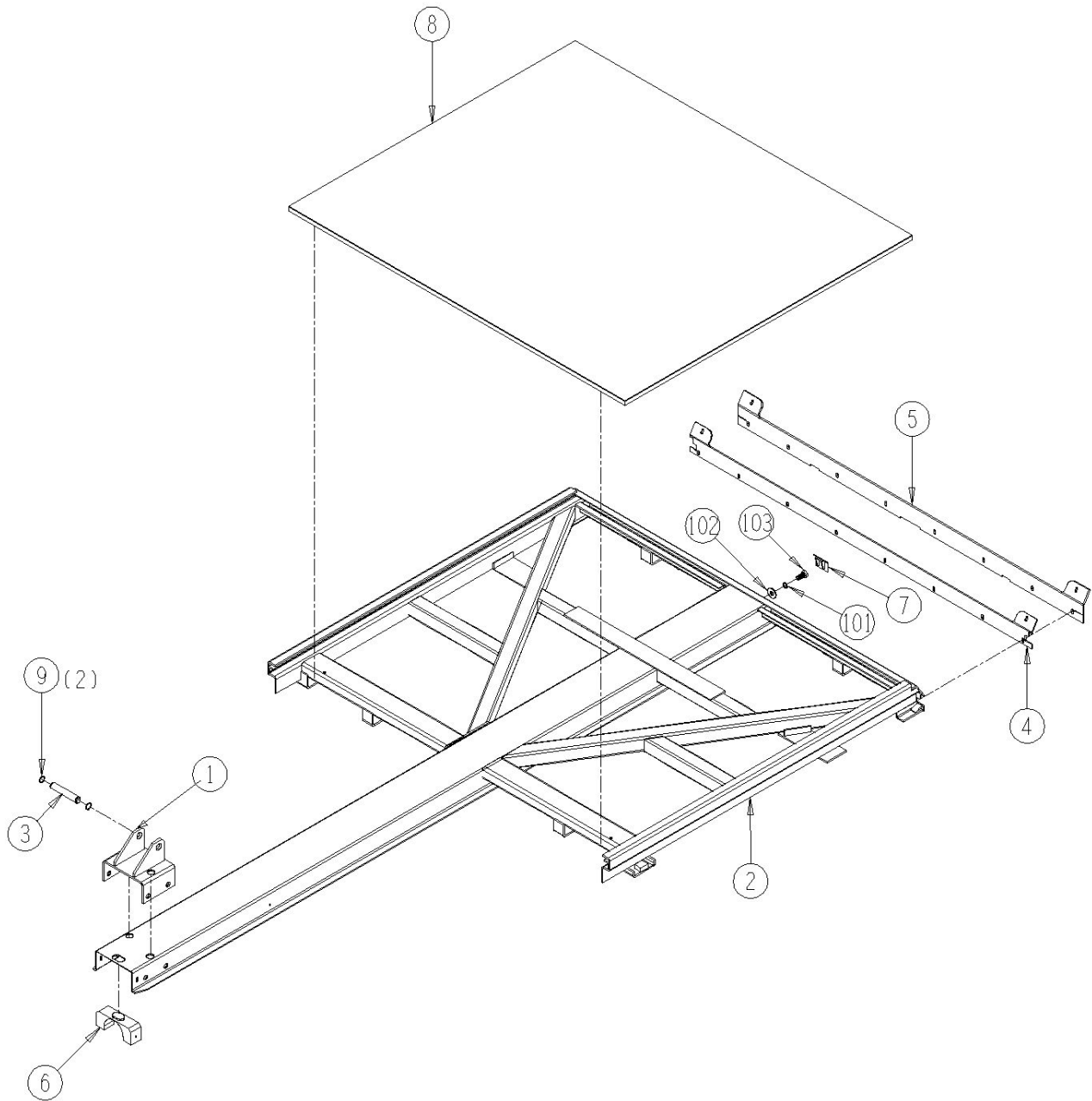

7103-1-4 Moving Panel

<u>Ref</u>	<u>Part No.</u>	<u>Description</u>	<u>Parts – Assembly</u>	<u>Will Fit SN</u>	<u>Remarks</u>
1	PR22463	Extension, Moving Panel, 1190	1		
2	PR25876	Moving Panel Wldmt, 1190	1		
3	PL-0024	Plastic, Nylon, 1-3/4" Hole Plug, Locking, Unvented	1		
4	PR33445	Retainer Bar, Side, Moving Panel	2		
5	PR33447	Belting, Moving Panel, Side	2		
6	PR33441	Flap, Moving Panel Scraper Belting, Bottom	1		
7	PR33443	Retaining Bar, Moving Panel, Bottom	1		
8	PR34750	Guide, Plastic, Cylinder Holder, Moving Panel	1		
9	PR34751	Guide, Plastic, Cylinder Mount, Lower, Moving Pnl	1		
10	PR34268	Retainer Bar, Top, Side Scraper, Moving Panel	2		
101	BL-6-075-C	3/8 UNC X 3/4 CARRIAGE BOLT GR5 ZINC	8		
102	BL-6-125-C	3/8 UNC X 1 1/4 CARRIAGE BOLT GR5 ZINC	24		
103	BL-6-150-C	3/8 UNC X 1 1/2 CARRIAGE BOLT GR5 ZINC	2		
104	BL-5-125-H	5/16-18 X 1 1/4 HEX CAP G5 ZC	8		
105	BL-M16-40	Hex Bolt, 16mm x 40mm	2		
106	BL-6-075-H	3/8-16 X 3/4 HHCS G5 ZC	2		
107	BL-6-SW	3/8 SAE FW ZC	26		
109	BL-10-FW-8	5/8" Grade 8 Flat Washer	2		
110	BL-5-FW	5/16 USS FW ZC	8		
111	BL-5-LW	5/16 SPLIT LW ZC	8		
113	BL-6-N	3/8-16 HEX NUTS ZC	34		
114	BL-6-LW	3/8 SPLIT LW ZC	36		

7103-1-4 MOVING PANEL

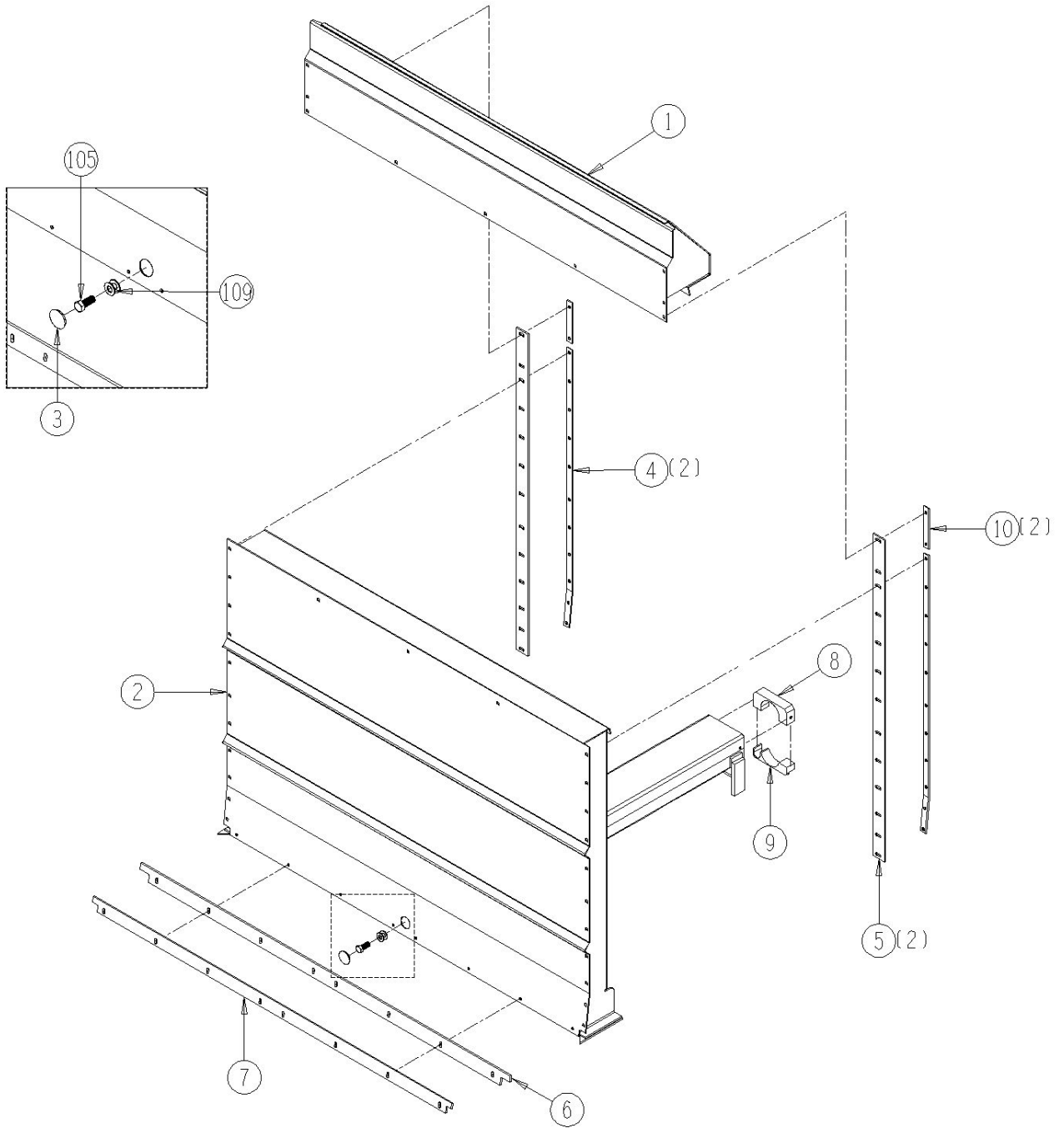

7103-1-5 Front Panel & Shields

<u>Ref</u>	<u>Part No.</u>	<u>Description</u>	<u>Parts – Assembly</u>	<u>Will Fit SN</u>	<u>Remarks</u>
1	PR22401	Shield, Left Side, Front Panel, Spreader	1		
2	PR22402	Panel, Front, Bearing & Shield Mount, Spreader	1		
2	PR22406	Panel, Front, Bearing & Shield Mount, 1190	0	71003001- 71007002 & 71007005	
3	PR23551	Hood, PTO Shield, Bolted to Front Panel, Spreader	1		
4	PR24569	Link, Shield, Front Panel	1		
5	LA-703	Large Rubber T Latch Assembly	1		
7	PIN-C2-16	Cotter Pin, 1/8" x 1"	1		
8	PR22478	Frame Support, 1190	1		
101	BL-8-125-C	1/2 UNC X 1 1/4 CARRIAGE BOLT GR5 ZINC	7		
102	BL-6-100-C	3/8 UNC X 1 CARRIAGE BOLT GR5 ZINC	4		
103	BL-6-075-C	3/8 UNC X 3/4 CARRIAGE BOLT GR5 ZINC	2		
104	RI-3-66-P	Pop Rivets 3/16 x 1/2 Domed, .625 head , ea.	2		
105	BL-8-SW	1/2 SAE FW ZC	8		
106	BL-6-FW	3/8 USS FW ZC	1		
107	BL-6-LN	3/8 UNC FIN HEX LOCK NUT NE A563 GrA ZINC	1		
108	BL-6-LW	3/8 SPLIT LW ZC	5		
109	BL-6-N	3/8-16 HEX NUTS ZC	5		
110	BL-6-SW	3/8 SAE FW ZC	7		
111	BL-8-N	1/2-13 HEX FIN NUTS ZC	8		
112	BL-8-LW	1/2 SPLIT LW ZC	8		

7103-1-5 FRONT PANELS & SHIELDS

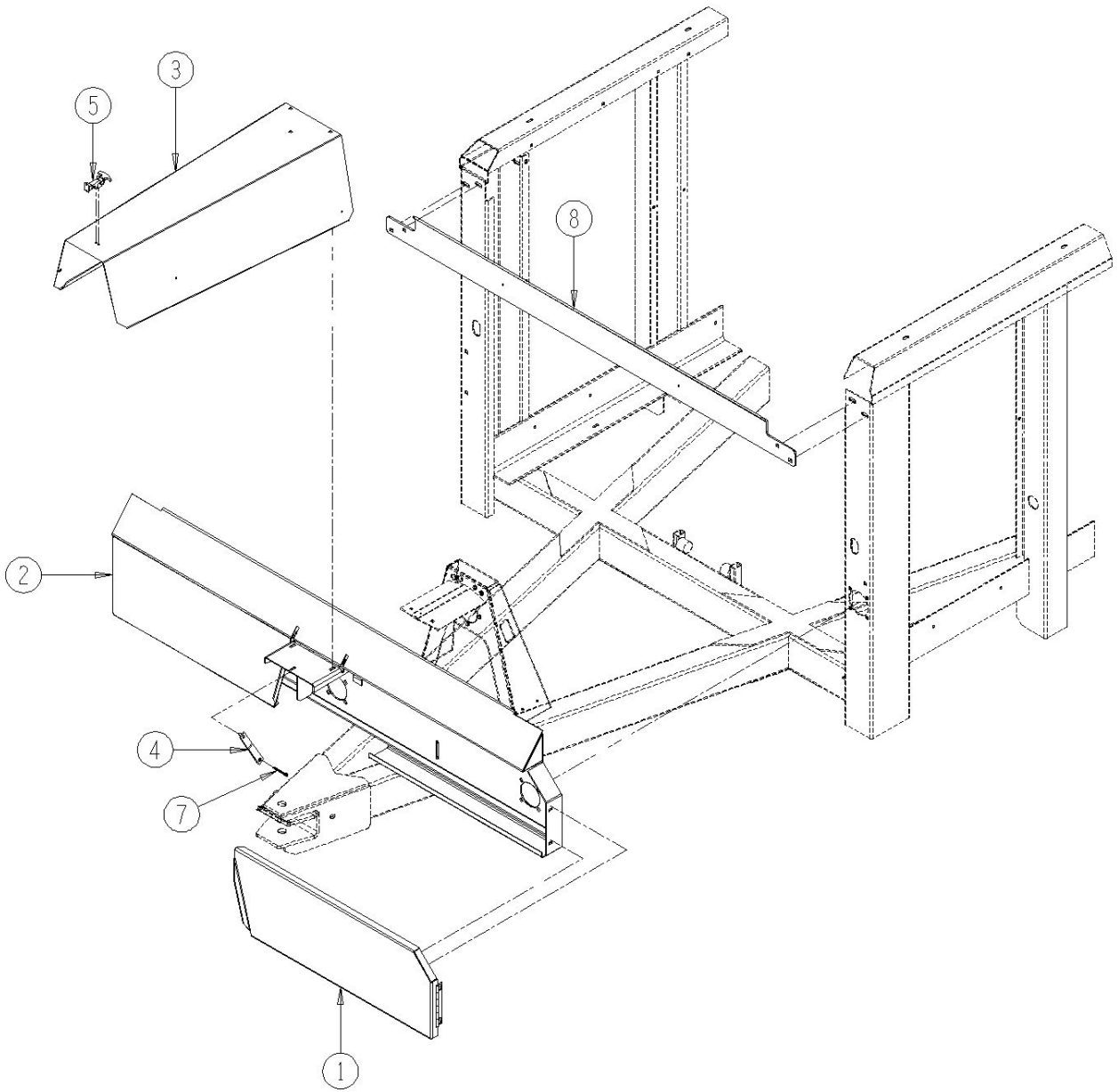

7103-1-6 Beater Support Panels

<u>Ref</u>	<u>Part No.</u>	<u>Description</u>	<u>Parts – Assembly</u>	<u>Will Fit SN</u>	<u>Remarks</u>
1	PR39031	Beater Panel, LH	1		
2	PR39036	Beater Panel, RH	1		
3	PR39032	Beater Ring Weldment, Main	1		
4	PR39034	Closure Wldmt, Interm Beater, LH	1		
101	BL-6-100-C	3/8 UNC X 1 CARRIAGE BOLT GR5 ZINC	12		
102	BL-6-175-C	3/8 UNC X 1 3/4 CARRIAGE BOLT GR5 ZINC	10		
103	BL-6-N	3/8-16 HEX NUTS ZC	22		
104	BL-6-LW	3/8 SPLIT LW ZC	22		
105	BL-6-SW	3/8 SAE FW ZC	22		

7103-1-6 BEATER SUPPORT PANELS

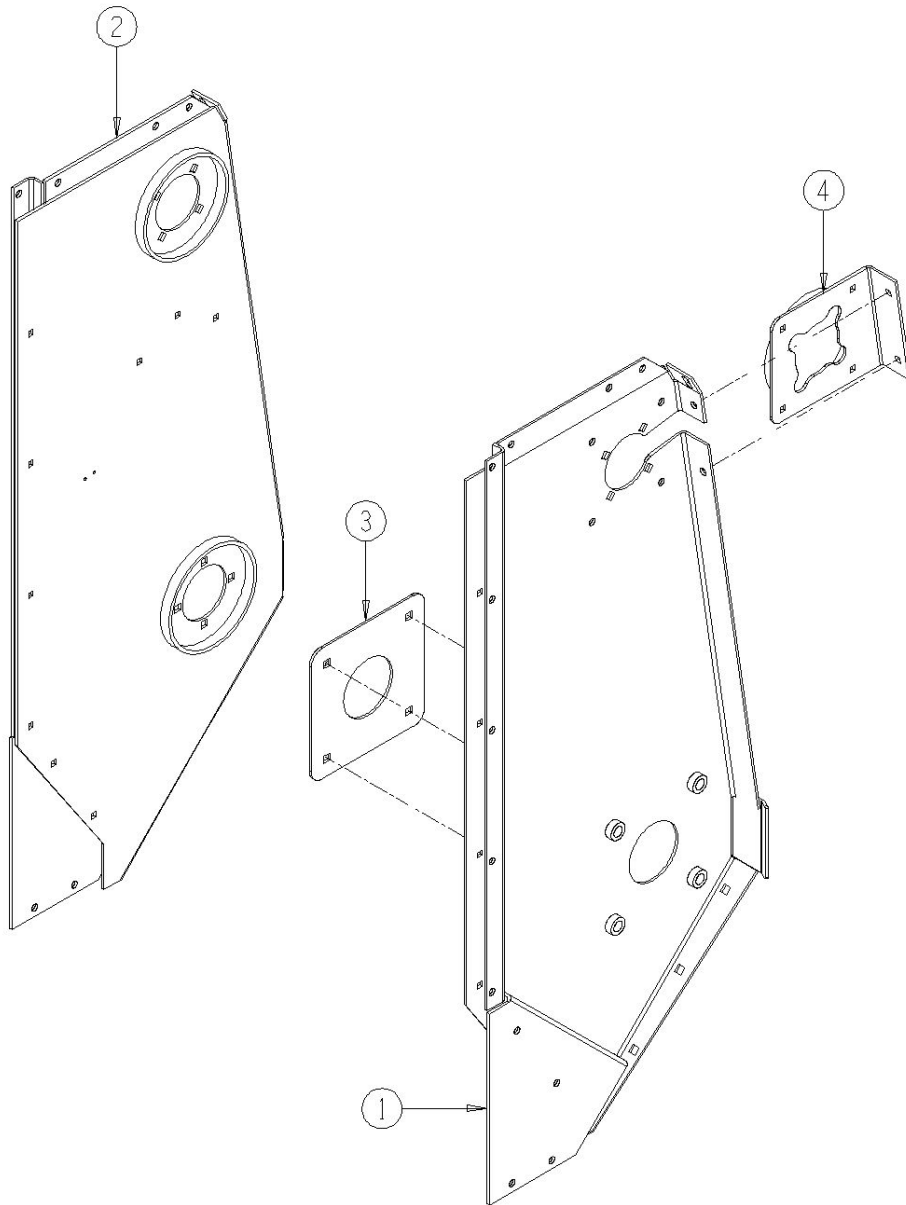

7103-1-6A Beater Support Panels, S.N.'s 71003001-71004018

<u>Ref</u>	<u>Part No.</u>	<u>Description</u>	<u>Parts – Assembly</u>	<u>Will Fit SN</u>	<u>Remarks</u>
1	PR39030	Panel, Beater Support, LH, 1190	1		
2	PR39035	Panel, Beater Support, RH, 1190	1		
3	PR39032	Beater Ring Weldment, Main	1		
4	PR39033	Beater Closure Weldment, Interm. Beater Ring	1		
101	BL-6-100-C	3/8 UNC X 1 CARRIAGE BOLT GR5 ZINC	12		
102	BL-6-175-C	3/8 UNC X 1 3/4 CARRIAGE BOLT GR5 ZINC	10		
103	BL-6-N	3/8-16 HEX NUTS ZC	22		
104	BL-6-LW	3/8 SPLIT LW ZC	22		
105	BL-6-SW	3/8 SAE FW ZC	22		

7103-1-6A BEATER SUPPORT PANELS
S.N.'S 71003001-71004018

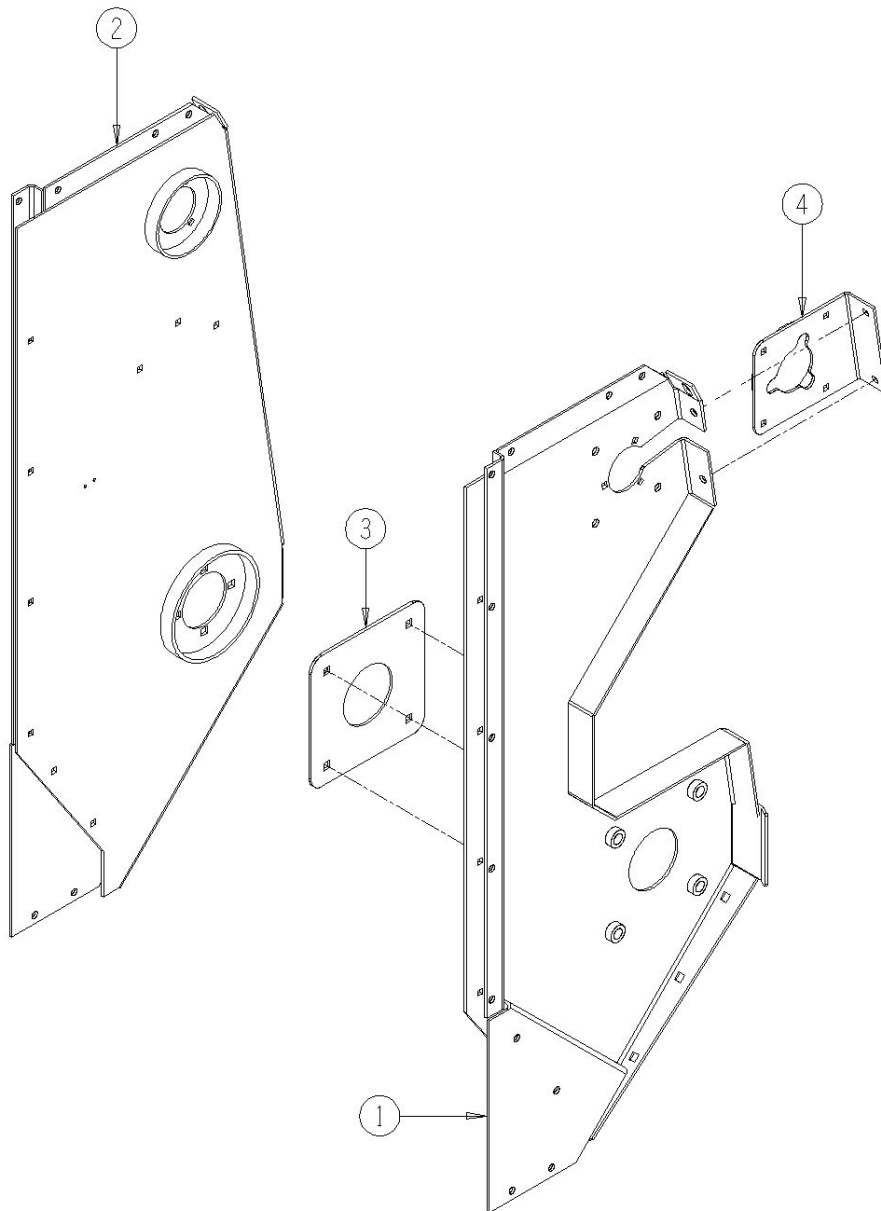

7103-1-7 Endgate

<u>Ref</u>	<u>Part No.</u>	<u>Description</u>	<u>Parts – Assembly</u>	<u>Will Fit SN</u>	<u>Remarks</u>
1	PR39050	Endgate Wldmt, 1190	1		
2	PR39063	Bar, Bottom, Belting Holder, End Gate, Spreader	1		
3	PR39064	Belting, Bottom, End Gate, Spreader	1		
4	PR39052	Hinge Pin, Endgate, 1190	2		
5	PR39056	Rubber Flap, Endgate, 1190	2		
6	PR39057	Retaining Bar, Endgate Flap, Vertical	2		
7	GF-1428	Grease Fitting 1/4" x 28 straight	2		
101	BL-12-450-8	3/4" x 4 1/2", HH C/S G8 ZC	2		
102	BL-10-300-H	5/8-11 X 3 HEX CAP G5 ZC	2		
103	BL-10-375-H	5/8-11 X 3 3/4 HEX CAP G5 ZC	2		
104	BL-6-125-C	3/8 UNC X 1 1/4 CARRIAGE BOLT GR5 ZINC	20		
105	BL-6-150-C	3/8 UNC X 1 1/2 CARRIAGE BOLT GR5 ZINC	2		
106	BL-10-SW	5/8 SAE FW ZC @	8		
107	BL-12-FW	3/4" Flat Washer	4		
108	BL-12-LN	3/4" Lock Nuts w/Nylon Inserts	2		
109	BL-10-LN	5/8-11 HEX LN NE ZC	4		
110	BL-6-N	3/8-16 HEX NUTS ZC	22		
111	BL-6-LW	3/8 SPLIT LW ZC	22		
112	BL-6-SW	3/8 SAE FW ZC	22		

7103-1-7 ENDGATE

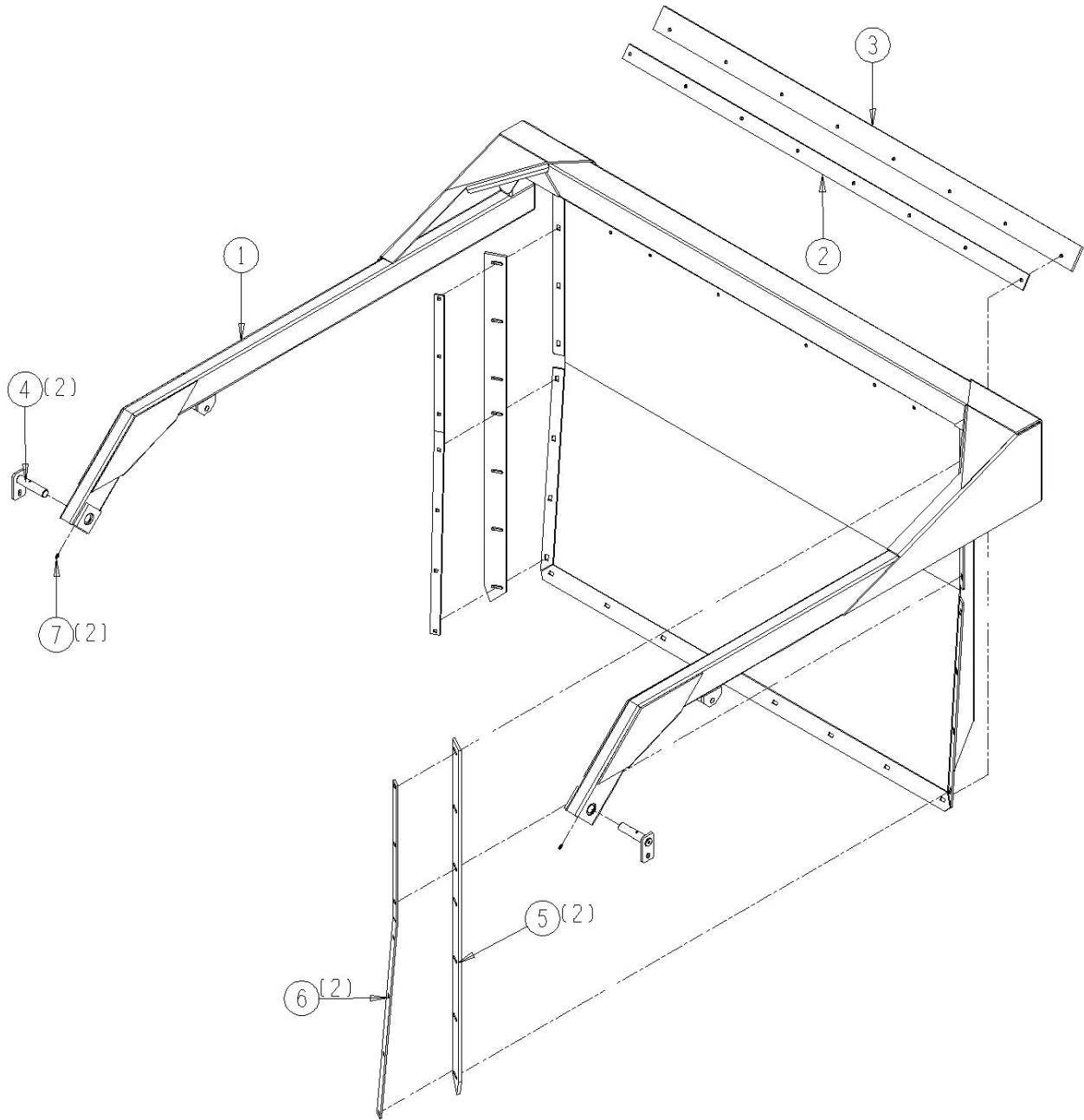

7103-1-8 Front Splash Guard

<u>Ref</u>	<u>Part No.</u>	<u>Description</u>	<u>Parts – Assembly</u>	<u>Will Fit SN</u>	<u>Remarks</u>
1	PR39182	Splash Guard, 790 & 1190	2		

7103-1-8
FRONT SPLASH GUARD

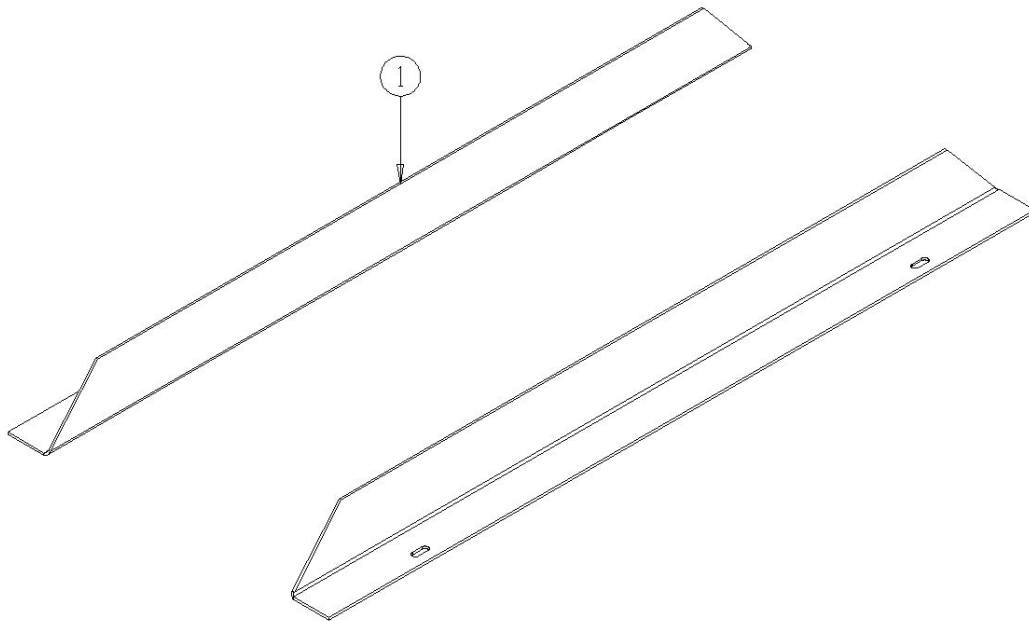

7103-1-9 End Pan

<u>Ref</u>	<u>Part No.</u>	<u>Description</u>	<u>Parts – Assembly</u>	<u>Will Fit SN</u>	<u>Remarks</u>
1	PR25110	Slurry Pan	1	PR25110	
2	BT-0081	Seal Slurry Pan 790 Spreader	1	BT-0081	
3	BAR-0081	Backing Bar Slurry Pan Spreader	1	BAR-0081	
4	BAR-0080	Belting Backing Bar 790 Slurry Pan	2	BAR-0080	
5	BT-0080	Belting Slurry Pan Spreader	2	BT-0080	
6	PR25111	Slurry Pan Right Side Mount	1	PR25111	
7	PR25112	Slurry Pan Left Side Mount	1	PR25112	
8	ADJ-0080	Adjuster Handle Slurry Pan	2	ADJ-0080	
9	ADJ-0082	Adjuster Linkage Slurry Pan Right	1	ADJ-0082	
10	ADJ-0081	Adjuster Linkage Slurry Pan Left	1	ADJ-0081	
11	ADJ-0083	Adjuster Pivot Slurry Pan	2	ADJ-0083	
12	BL-6-100-C	3/8 UNC X 1 CARRIAGE BOLT GR5 ZINC	23		
13	BL-6-SW	3/8 SAE FW ZC	23		
14	BL-6-LW	3/8 SPLIT LW ZC	23		
15	BL-6-N	3/8-16 HEX NUTS ZC	23		
16	BL-8-125-C	1/2 UNC X 1 1/4 CARRIAGE BOLT GR5 ZINC	6		
17	BL-8-SW	1/2 SAE FW ZC	6		
18	BL-8-LW	1/2 SPLIT LW ZC	6		
19	BL-8-N	1/2-13 HEX FIN NUTS ZC	6		
20	PIN-4-28	Roll Pin 1/4" x 1.75"	6		
21	ADJ-0084	Locking Bar, Slurry Pan	2		
22	PIN-250L	1/4" Lynch Pin	2		
23	GF-1428	Grease Fitting 1/4" x 28 straight	6		

7103-1-9
SLURRY PAN S.N. 71006001-

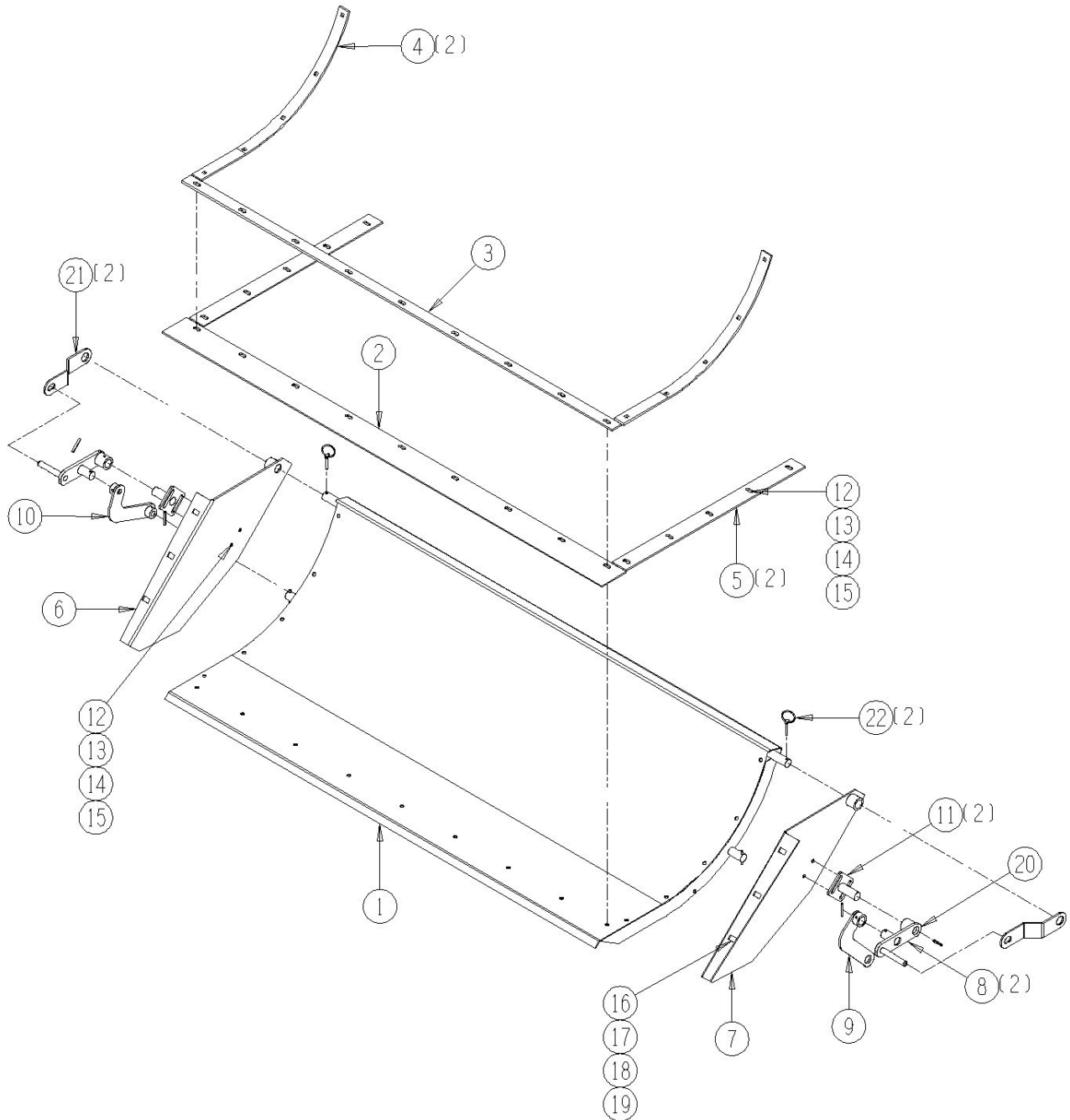

7103-1-10 Walking Beam

<u>Ref</u>	<u>Part No.</u>	<u>Description</u>	<u>Parts – Assembly</u>	<u>Will Fit SN</u>	<u>Remarks</u>
1	PR22972	Rocker, LH, 1190, 4½" Center Shaft, 4" Spindles	1		
2	PR22973	Rocker, RH, 1190, 4½" Center Shaft, 4" Spindles	1		
3	PR43596	Retaining Ring, 4 1/2", External	2		
4	PR34415	Bronze Bushing for Spreader, 4½" Dia Shaft	4		
5	GF-1827-65L	Grease Fitting 1/8 NPT Long 65°	2		
6	H2-20-2MP-2MP	1/8in Grease Hose x 1/8MP x 1/8MP x 20in Long	2		
7	DC-0010	Decal, Grease Every 10 hrs.	2		
8	A-1501-2-2	1/8" MP x 1/8" FPX90°	2		
9	A-1404-2-2	1/8 MP x 1/8 FPX	2		

7103-1-10
WALKING BEAM

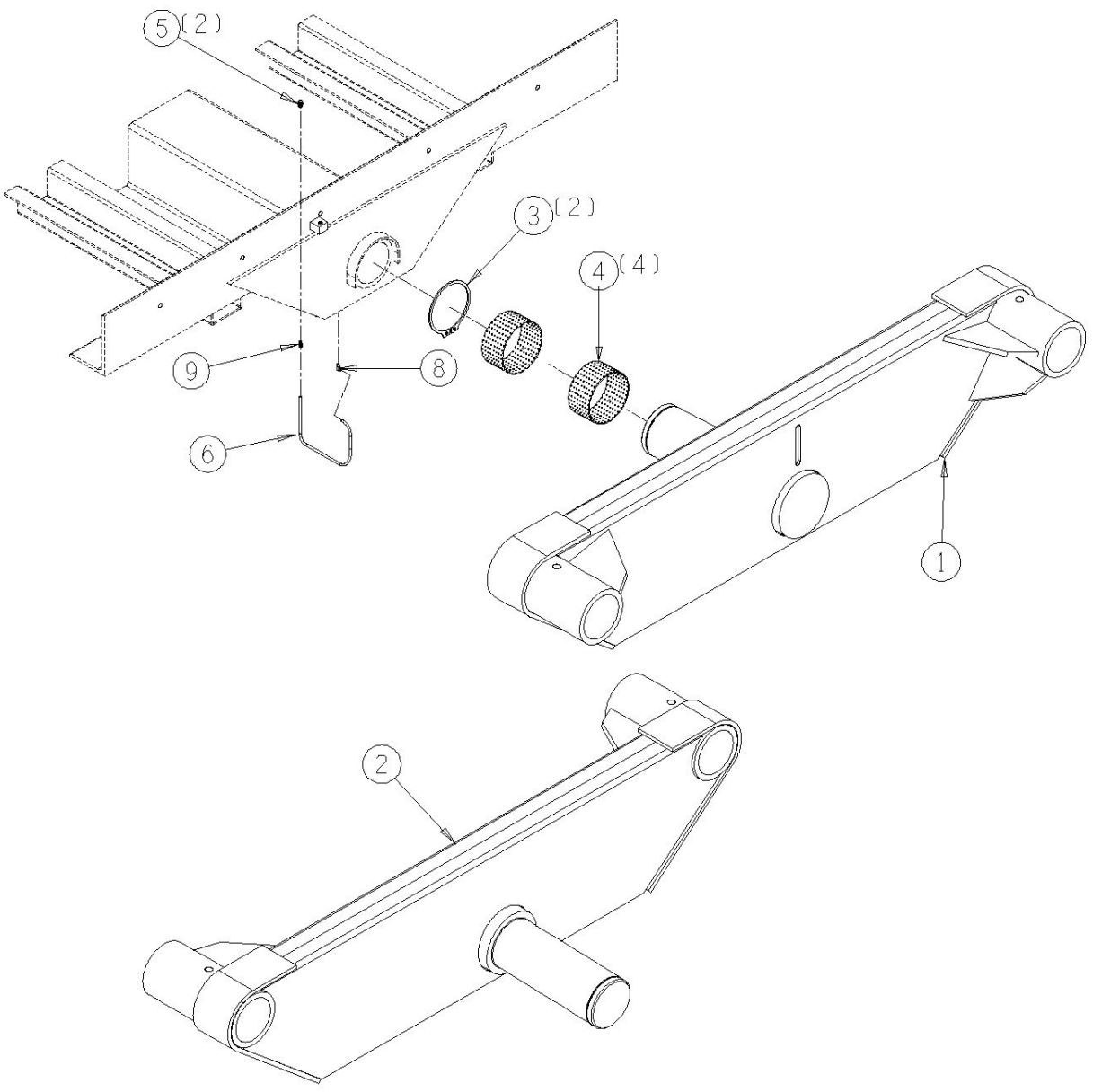

7103-1-10A Walking Beam, S.N.'s 71003001-71004020

<u>Ref</u>	<u>Part No.</u>	<u>Description</u>	<u>Parts – Assembly</u>	<u>Will Fit SN</u>	<u>Remarks</u>
1	PR22968	Rocker, LH, 4½" Center Pivot, 4" Spindles	1	71003001- 71004020	
2	PR22969	Rocker, RH, 4½" Center Pivot, 4" Spindles	1	71003001- 71004020	Only hard copies of drawings remain
3	PR22960	Rocker Shaft, 4½" Dia	2		
4	PR22961	Retainer, Rocker	2		
5	GF-1428	Grease Fitting 1/4" x 28 straight	4		
6	PR22964	Pin, Rocker to Axle	2		
7	PIN-6-32	Roll Pin 3/8" x 2"	4		

7103-1-10A WALKING BEAM

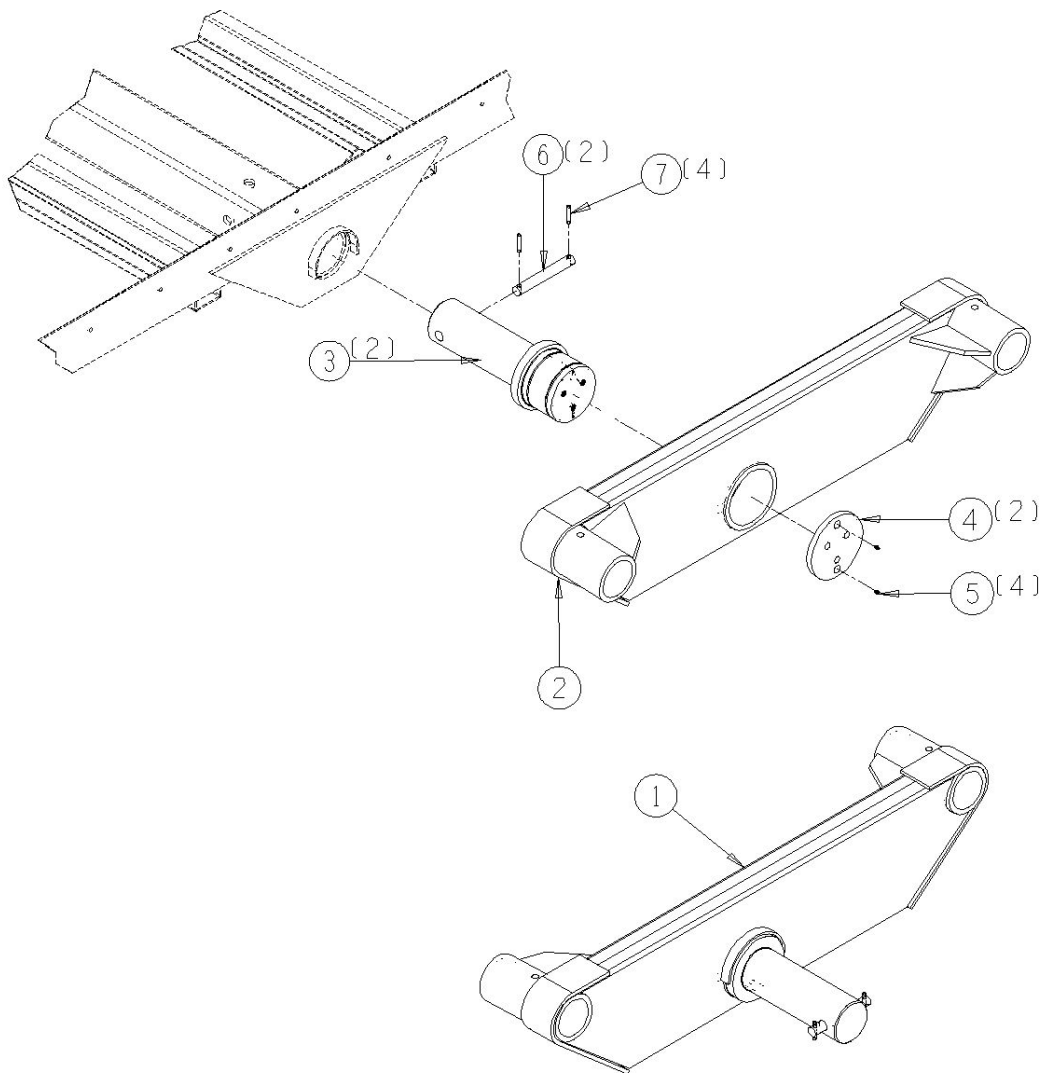

7103-1-11 Hubs & Spindle, Tires & Wheels, Implement

<u>Ref</u>	<u>Part No.</u>	<u>Description</u>	<u>Parts – Assembly</u>	<u>Will Fit SN</u>	<u>Remarks</u>
1	WHL-1210	Hub and Spindle Assembly	4		
2	WHM-7101	550/60-22.5 Tire & Wheel Assy	4	1190	
800	WBR-1210K	Wheel Bearing Kit for WHL-1210 Hub & Spindle Assy.	1	WHL-1210	inner & outer cones & cups and grease seal
801	WHL-1210A	Inner Cup	1		
802	WHL-1210B	Outter Cup	1		
803	WHL-1210C	Inner Cone	1		
804	WHL-1210D	Outer Cone	1		
805	WHL-1210E	Dust Cap	1		
806	WHL-1210F	Grease Seal	1		
807	WHL-1210G	Flange Nut, Spindle	1		
808	WHL-1210H	Washer, Spindle	1		
809	WHL-1210I	Cotter Pin, Spindle	1		
810	WHL-1210J	Wheel Stud Bolt	8		
811	WHL-1210K	Wheel Stud Nut	8		
812	WHL-1210L	Wheel Stud Washer	8		
813	WHL-7104	Wheel, 16 x 22.5 - 7/15, 3/8" (+) Offset, HD, Painted	1	WHL-7101	
814	WHT-7101	Tire, Implement, 560/60-22.5, 404 Tread	1		
815	WHL-1210M	Spindle	1		

7103-1-11
HUBS & SPINDLE, TIRES & WHEELS, IMPLEMENT

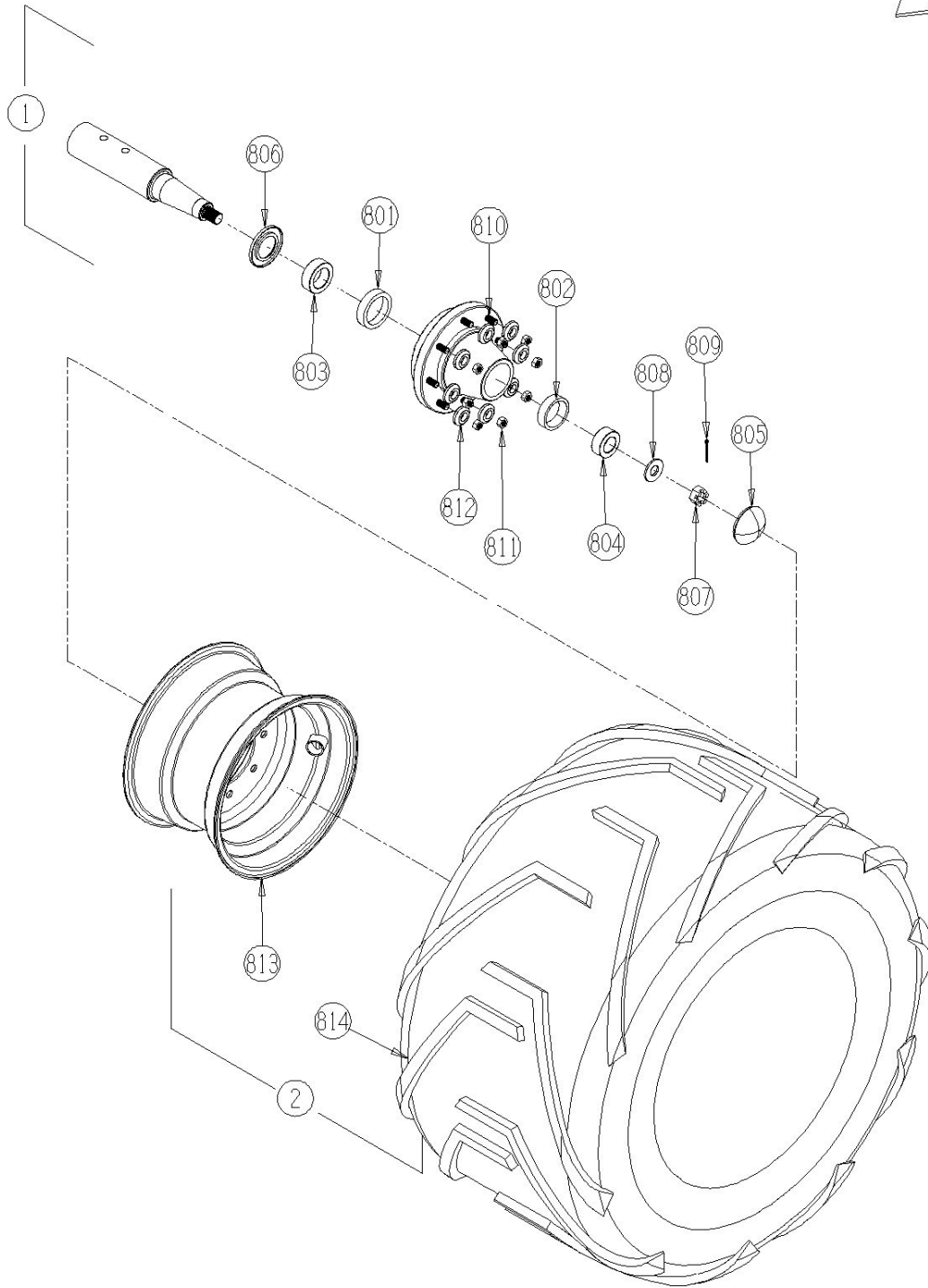

7103-1-12 Hubs & Spindles, Tires & Wheels, Truck

<u>Ref</u>	<u>Part No.</u>	<u>Description</u>	<u>Parts – Assembly</u>	<u>Will Fit SN</u>	<u>Remarks</u>
1	WHL-1210	Hub and Spindle Assembly	4		
2	WHM-7105	425/65R22.5 Tire & Wheel Assy	4	1190	
800	WBR-1210K	Wheel Bearing Kit for WHL-1210 Hub & Spindle Assy.	1	WHL-1210	inner & outer cones & cups and grease seal
801	WHL-1210A	Inner Cup	1		
802	WHL-1210B	Outter Cup	1		
803	WHL-1210C	Inner Cone	1		
804	WHL-1210D	Outer Cone	1		
805	WHL-1210E	Dust Cap	1		
806	WHL-1210F	Grease Seal	1		
807	WHL-1210G	Flange Nut, Spindle	1		
808	WHL-1210H	Washer, Spindle	1		
809	WHL-1210I	Cotter Pin, Spindle	1		
810	WHL-1210J	Wheel Stud Bolt	8		
811	WHL-1210K	Wheel Stud Nut	8		
812	WHL-1210L	Wheel Stud Washer	8		
813	WHL-7105	22.5 X 13 Wheel	1	WHM-7105	
814	WHT-7105	Used Truck Tire 425/65R22.5	1		
815	WHL-1210M	Spindle	1		

7103-1-12
HUBS & SPINDLES, TIRES & WHEELS, TRUCK

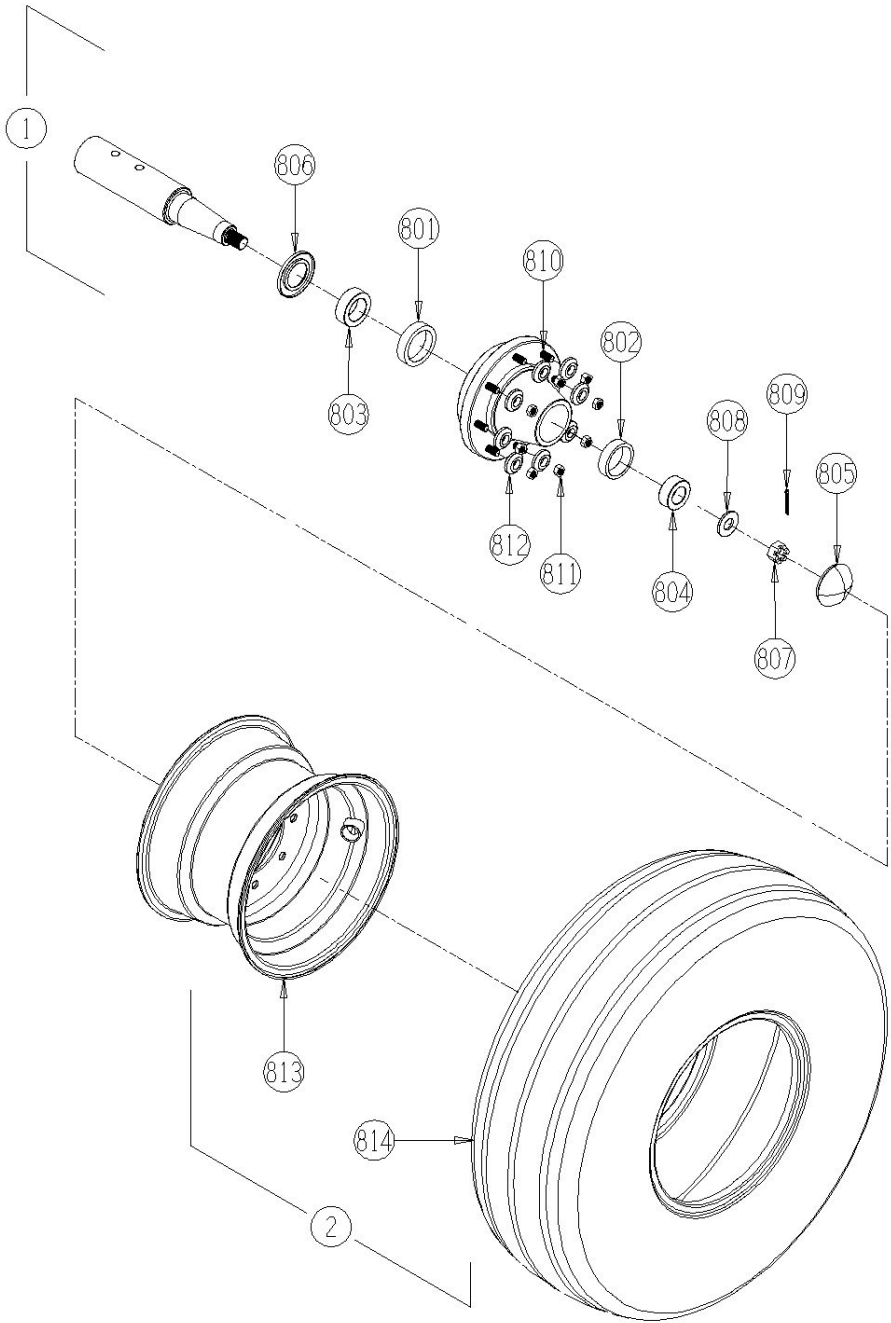

7103-1-13 Optional Endgate Debris Belting, Standard Upper Beater

<u>Ref</u>	<u>Part No.</u>	<u>Description</u>	<u>Parts – Assembly</u>	<u>Will Fit SN</u>	<u>Remarks</u>
1	PR50200	Belting,Endgate Flap	1		
2	PR50201	Flat Bar	1		
100	BL-6-175-C	3/8 UNC X 1 ¼ CARRIAGE BOLT GR5 ZINC	6		
101	BL-6-FW	3/8 USS FW ZC	6		
102	BL-6-LW	3/8 SPLIT LW ZC	6		
103	BL-6-N	3/8-16 HEX NUTS ZC	6		

7103-1-13
OPTIONAL ENDGATE BELTING, STANDARD UPPER BEATER

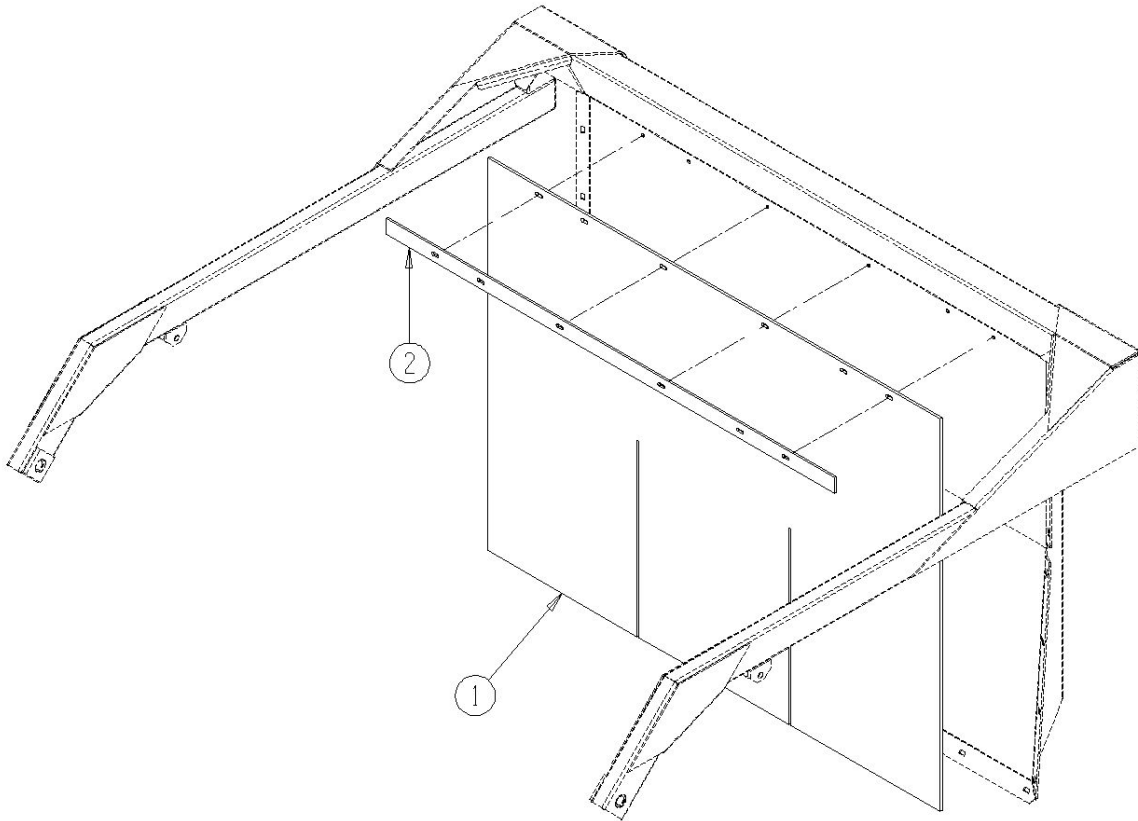

7103-2-1 1000 rpm Constant Velocity Driveline w/ Clutch

<u>Ref</u>	<u>Part No.</u>	<u>Description</u>	<u>Parts – Assembly</u>	<u>Will Fit SN</u>	<u>Remarks</u>
0	PTB-1012	1000 rpm CV Driveline for Hydra Ram Spreader	0		S.N. -71007008 Can Replace PTS-1010
801	PTB-1012A	Yoke, 1-3/8" - 21 Spline	1		
802	PTB-1012B	Outer Profile	1		
803	PTB-1012C	Inner Profile	1		
804	PTB-1012D	Friction Clutch	1		
805	PTB-1012E	Outer Shield Tube	1		
806	PTB-1012F	Inner Shield Tube	1		
807	PTB-1012G	Support Bearing	1		
808	PTB-1012H	Cross Journal Ass.	2		
809	PTB-1012I	Circlip	12		
810	PTB-1012J	Grease Nipple - 45°	3		
811	PTB-1012K	Central Body	1		
812	PTB-1012L	Yoke With Bridge	1		
813	PTB-1012M	Grease Nipple - Straight	1		
814	PTB-1012N	Flexible Pin	1		
815	PTB-1012O	Flexible Pin	1		
816	PTB-1012P	Inner Tube Yoke	1		
817	PTB-1012Q	Cross Journal Ass.	1		
818	PTB-1012R	Label	1		
819	PTB-1012S	Shield Support 6-7	1		
820	PTB-1012T	Safety Cone	1		
821	PTB-1012U	I.Cone Sets F5-6-7	1		
822	PTB-1012V	Shield Support 6-7	1		
823	PTB-1012W	Complete Chain	3		
824	PTB-1012X	Ring Nut Dowels	1		
825	PTB-1012Y	Complete Shell	1		
826	PTB-1012Z	Label	1		

827	PTB-1012AA	Complete Push Button	2
828	PTB-1012BB	Hub	1
829	PTB-1012NN	Outer Half Shaft	1
830	PTB-1012OO	Inner Half Shaft	1
831	PTB-1012PP	Outer Half Shaft, Front Half	1
832	PTB-1012QQ	Inner Half Shaft	1
833	PTB-1012RR	Outer Shield	1
834	PTB-1012SS	Inner Shield	1
835	PTB-1012TT	Complete Shield	1

7103-2-1 1000 RPM, CONSTANT VELOCITY DRIVELINE, W/ CLUTCH

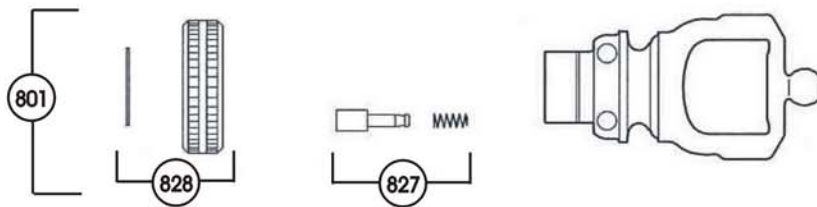
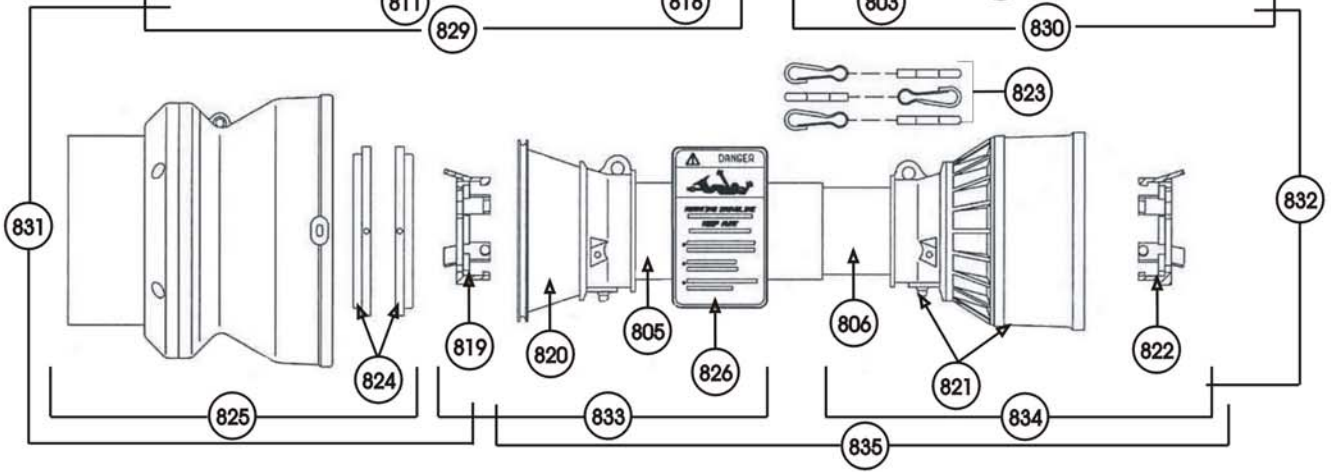
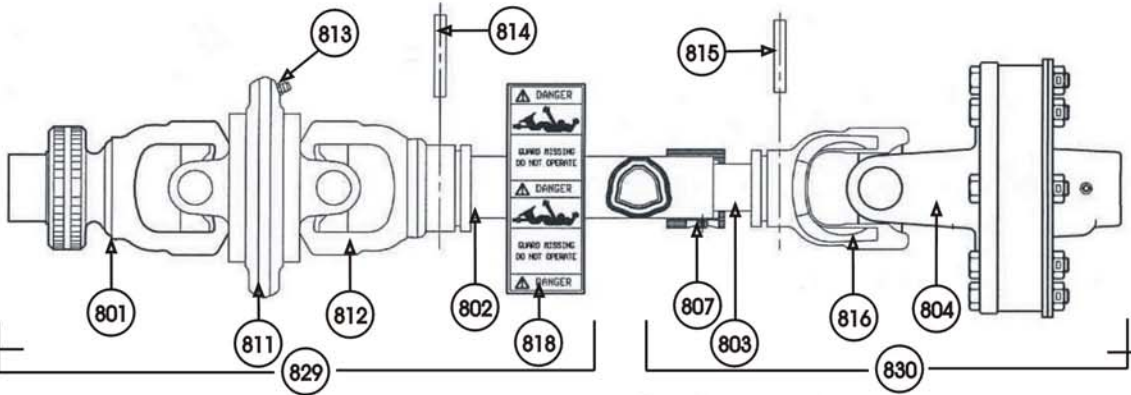
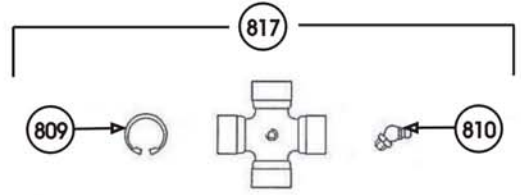
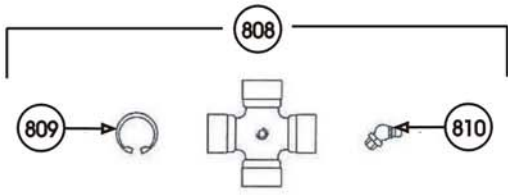

7103-2-1A 1000 RPM Con. Vel. Shaft w/Clutch, S.N. 71007009-

<u>Ref</u>	<u>Part No.</u>	<u>Description</u>	<u>Parts – Assembly</u>	<u>Will Fit SN</u>	<u>Remarks</u>
0	PTB-1012	1000 rpm CV Driveline for Hydra Ram Spreader	1		S.N. -71007008 Can Replace PTS-1010
801	PTB-1012A	Yoke, 1-3/8" - 21 Spline	1		
802	PTB-1016E	Cross Kit, S6 SFT 80° , EL 27x100	2		
805	PTB-1011C	Outer Tube Yoke, 1R6	1		
806	PTB-1011D	Central Body Sft, CV S6	1		
808	PTB-1011E	Flexible Roll Pin, #6/7 Outer 10X75MM	1		
812	PTB-1011F	Outer Tube	1		
813	PTB-1011G	Inner Drive Tube	1		
816	PTB-1012O	Flexible Pin	1		
817	PTB-1012P	Inner Tube Yoke	1		
821	PTB-1011H	Clutch, #6-S7, 1-1/2"	1		
822	PTB-1011I	Cross Kit	1		
825	PTB-1011J	Shield Cone, 80° CV	1		
826	PTB-1012S	Shield Support 6-7	1		
827	PTB-1011K	Shield Support Sft	1		
828	PTB-1011L	Self Tapping Shielding Screw	6		
829	PTB-1011M	Tube	1		
830	PTB-1011N	Shield Tube	1		
832	PTB-1012V	Shield Support 6-7	1		
833	PTB-1011O	Base Cone, Outer for 80° CV	1		
834	PTB-1011P	Washer	5		
835	PTB-1012U	I.Cone Sets F5-6-7	1		
840	PTB-1011Q	Shield Chain, S-Hook	3		
841	PTB-1011R	Clip-Chain Attachment	1		
845	PTB-1012G	Support Bearing	1		
848	PTB-1012R	Label	1		
849	PTB-1012Z	Label	1		

850	PTB-1011S	Instruction Booklet, USA	1	
851	PTB-1011T	Ball Collar Kit, 1-3/8"	1	
860	PTB-1011U	Clutch Pin	4	
861	PTB-1012JJ	Spring Dowels	1	
862	PTB-1011V	Bolt-Nut, Pkg of 8	1	Packs of 8
863	PTB-1011W	Clutch Plate	1	
864	PTB-1012EE	Bushing	1	
865	PTB-1012FF	Friction Disk	4	
866	PTB-1012GG	Lining Plate	1	
867	PTB-1011X	Inner Plate	1	
868	PTB-1012II	Hub	1	
869	PTB-1012KK	Thrust Plate	1	
870	PTB-1012MM	Spacer	1	
871	PTB-1011Y	Spring	1	
893	PTB-1011Z	Half Shaft, Cleared	1	
894	PTB-1011AA	Half Shaft, Cleared	1	
897	PTB-1011BB	Shield, Complete Kit	1	

7103-2-1A 1000 RPM, CONSTANT VELOCITY DRIVELINE, W/ CLUTCH
S.N.71007009-

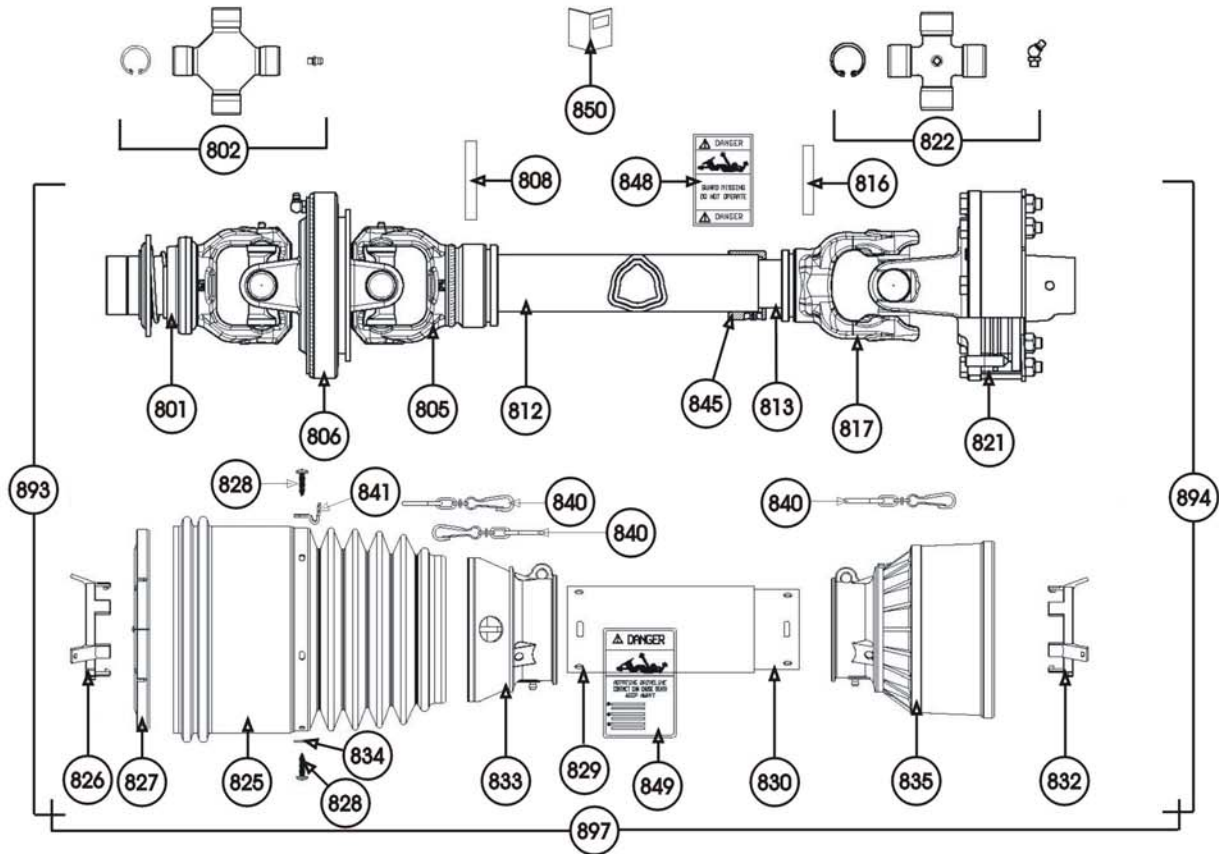

801

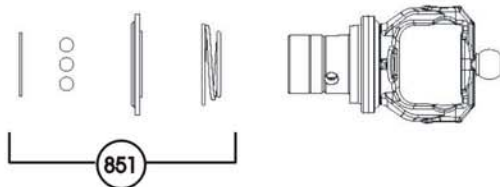

821

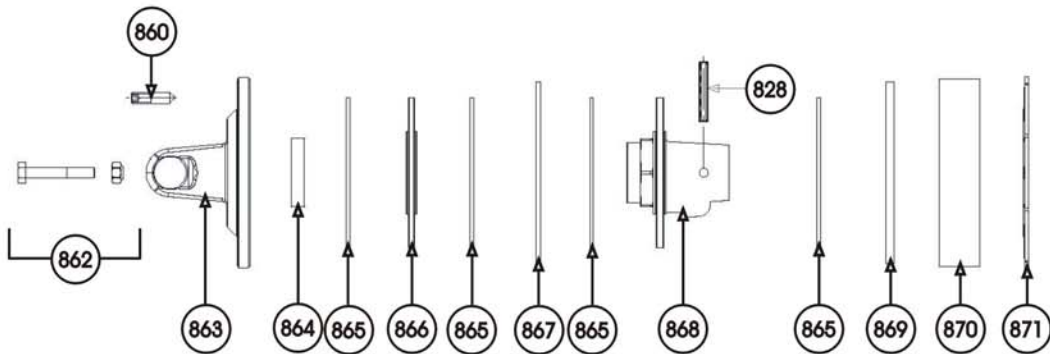

7103-2-2 Friction Clutch

<u>Ref</u>	<u>Part No.</u>	<u>Description</u>	<u>Parts – Assembly</u>	<u>Will Fit SN</u>	<u>Remarks</u>
0	PTB-1012D	Friction Clutch	0		
801	PTB-1012CC	Hex cap screw and lock nut	8		
802	PTB-1012DD	Flange Yoke	1		
803	PTB-1012EE	Bushing	1		
804	PTB-1012FF	Friction Disk	4		
805	PTB-1012GG	Lining Plate	1		
806	PTB-1012HH	Inner Plate	1		
807	PTB-1012II	Hub	1		
808	PTB-1012JJ	Spring Dowels	1		
809	PTB-1012KK	Thrust Plate	1		
810	PTB-1012LL	Spring	2		
811	PTB-1012MM	Spacer	1		

7103-2-2 FRICTION CLUTCH

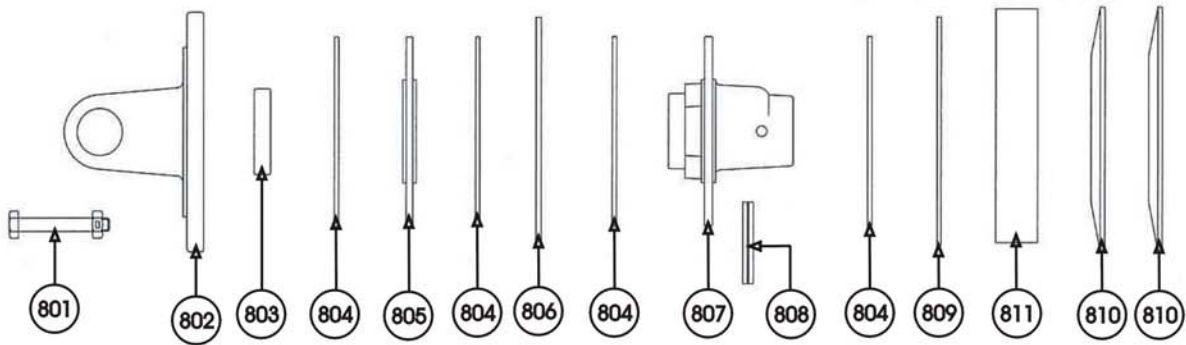

7103-2-4 Front Input Shaft, Sprockets & Chain

<u>Ref</u>	<u>Part No.</u>	<u>Description</u>	<u>Parts – Assembly</u>	<u>Will Fit SN</u>	<u>Remarks</u>
1	PR22867	Chain Sprocket, Rear Drive, Jack Shaft	1		
2	PR28139	Cap, Input Drive	1		
3	PR23168	Sprocket Wldmt, 1000 rpm, 790 & 1190	0	790, 1190	
3	PR23171	Sprocket Weldment, Front Drive Sprocket, 1190	1		
4	RLT-035-228	Roller 3.5 dia x 2.2 x 1/2" bore, no flange	1		
5	PR33227	Jack Shaft for 790, 1190, & 490V	1	790 & 1190	
6	BR-209-085	Bearing, Taper Bore, 1 1/2"	1		
7	BR-209-085A	Adapter for Taper Bore Bearing, 1 1/2"	1		50mm LTB
8	BR-085-MS	Stamped Bearing Housing for 1 3/4" Bearing	6		
9	BR-175-085-KB-I	Bearing, 1 3/4" ID, SS	2		
10	PR38651	Spacer	1	PR38651	
12	BR-125-072-KB-I	Bearing, 1 1/4" ID, SS	0		
12	BR-144-072KB-I	Bearing, 1 7/16" ID, SS	1		
13	BR-072-MST	Stamped Bearing Housing for 1 1/4" Bearing, Two Bolt	2		
14	CH-60H-135	Roller Chain 135 pitches #60H Gearbox Drive w/master	1		1,000 rpm
101	BL-8-125-C	1/2 UNC X 1 1/4 CARRIAGE BOLT GR5 ZINC	8		
102	BL-6-100-C	3/8 UNC X 1 CARRIAGE BOLT GR5 ZINC	2		
103	BL-8-175-C	1/2 UNC X 1 3/4 CARRIAGE BOLT GR5 ZINC	4		
104	BL-8-400-C	1/2 UNC X 4 CARRIAGE BOLT GR5 ZINC	1		
105	BL-8-LW	1/2 SPLIT LW ZC	12		
106	BL-6-LW	3/8 SPLIT LW ZC	2		
107	BL-6-N	3/8-16 HEX NUTS ZC	2		
108	BL-6-SW	3/8 SAE FW ZC	2		
109	BL-8-LN	1/2-13 HEX LOCK NUT NYLON INSERT ZC	5		
110	BL-8-N	1/2-13 HEX FIN NUTS ZC	12		
111	BL-8-SW	1/2 SAE FW ZC	14		
801	PR23166	Sprocket Wldmt, 540 rpm 790 Heavy	1		
802	CH-60H-125	Roller Chain 125 pitches #60H Gearbox Drive w/master	1		540 rpm drive. Replaces CH-60H-127

7103-2-4 FRONT INPUT SHAFT SPROCKETS AND CHAIN

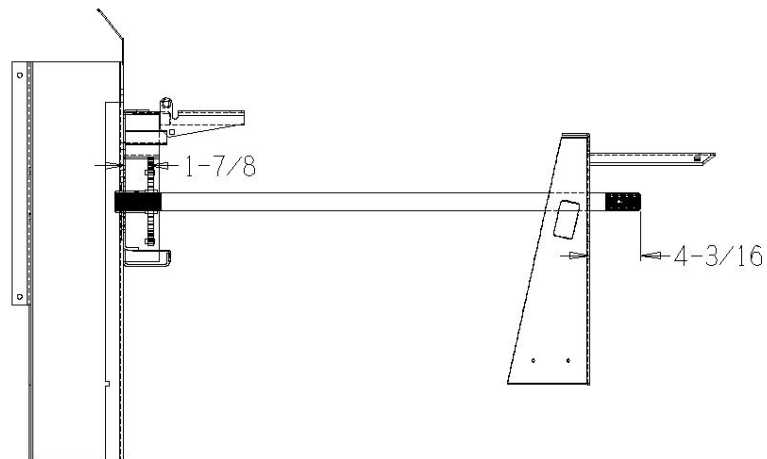
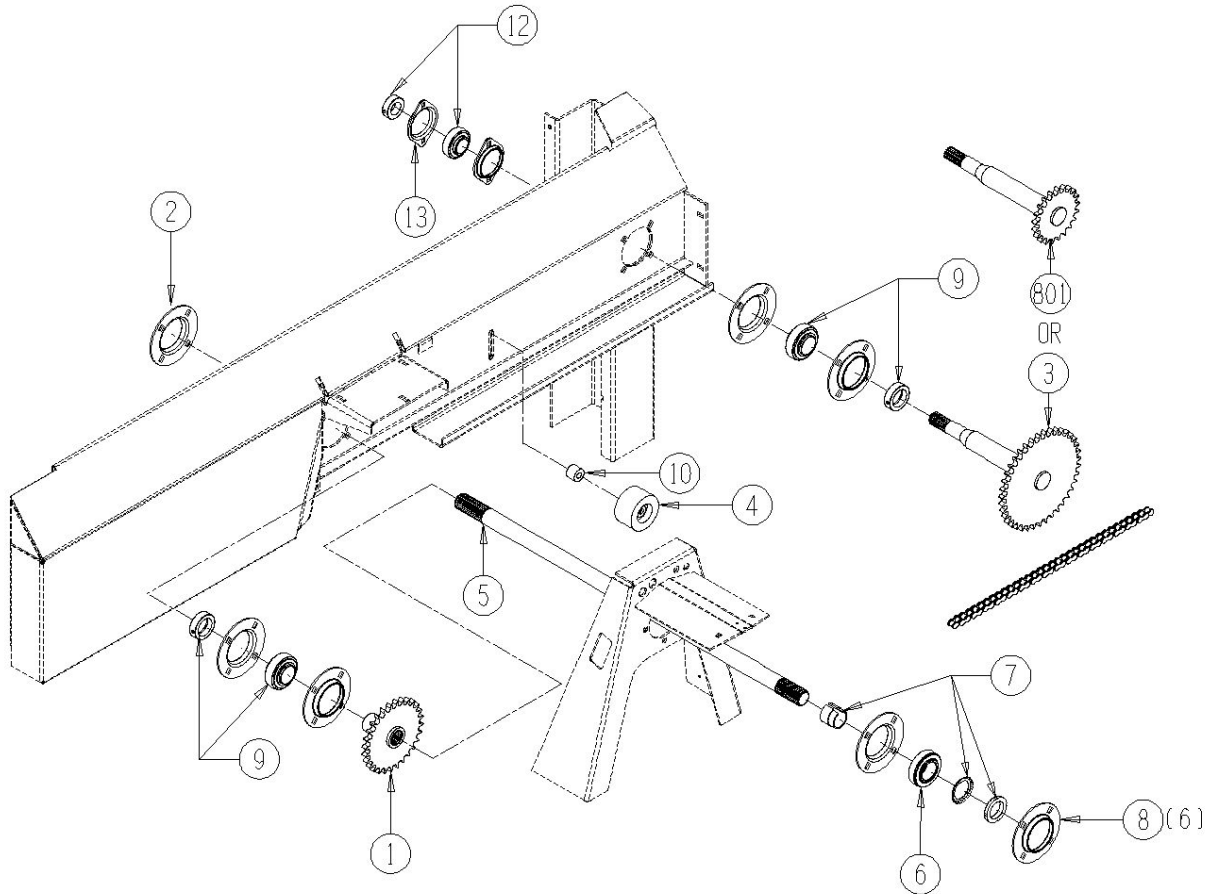

7103-2-5 Side Drive Shaft & Shields

<u>Ref</u>	<u>Part No.</u>	<u>Description</u>	<u>Parts – Assembly</u>	<u>Will Fit SN</u>	<u>Remarks</u>
1	PR33270	Side Shaft, Input To Gearbox, 1.25"	0		Special Order Only. Replace with upgrade kit
1	PR33274	Side Shaft, Input To Gearbox, 1 7/16"	1		
2	PR34863	Shield, Side Shaft, Front, 1190	2		
3	PR39090	Shield, Shaft, Side Interm, Spreader	1		
4	PR34862	Shield, Side Shaft, Near to Rear, 1190	1		
5	PR34861	Shield, Shaft, Side, Rear, Spreader	1		
6	PR39023	Bracket, Rear Shield, Spreader	1		
7	PR35344	Coupler, 1.75 O.D. x 30mm I.D. Splined & Hardened	0		
7	PR35351	Coupler, Front, Side Shaft	1		
8	PIN-4-28	Roll Pin 1/4" x 1.75"	1		
9	BR-072-MST	Stamped Bearing Housing for 1 1/4" Bearing, Two Bolt	4		
10	BR-125-072-KB-I	Bearing, 1 1/4" ID, SS	0		
10	BR-144-072KB-I	Bearing, 1 7/16" ID, SS	2		
11	PR35352	Coupler, Rear, Side Shaft, 1190	1		
101	BL-4-075-H	1/4 UNC X 3/4 HH C/S BOLT GR5 ZINC	19		
102	BL-6-100-C	3/8 UNC X 1 CARRIAGE BOLT GR5 ZINC	4		
103	BL-4-LW	1/4 SPLIT LW ZC	19		
104	BL-4-FW	1/4 USS FW ZC	19		
105	BL-6-N	3/8-16 HEX NUTS ZC	4		
106	BL-6-LW	3/8 SPLIT LW ZC	4		
107	BL-6-SW	3/8 SAE FW ZC	4		

7103-2-5 SIDE DRIVE SHAFT & SHIELDS

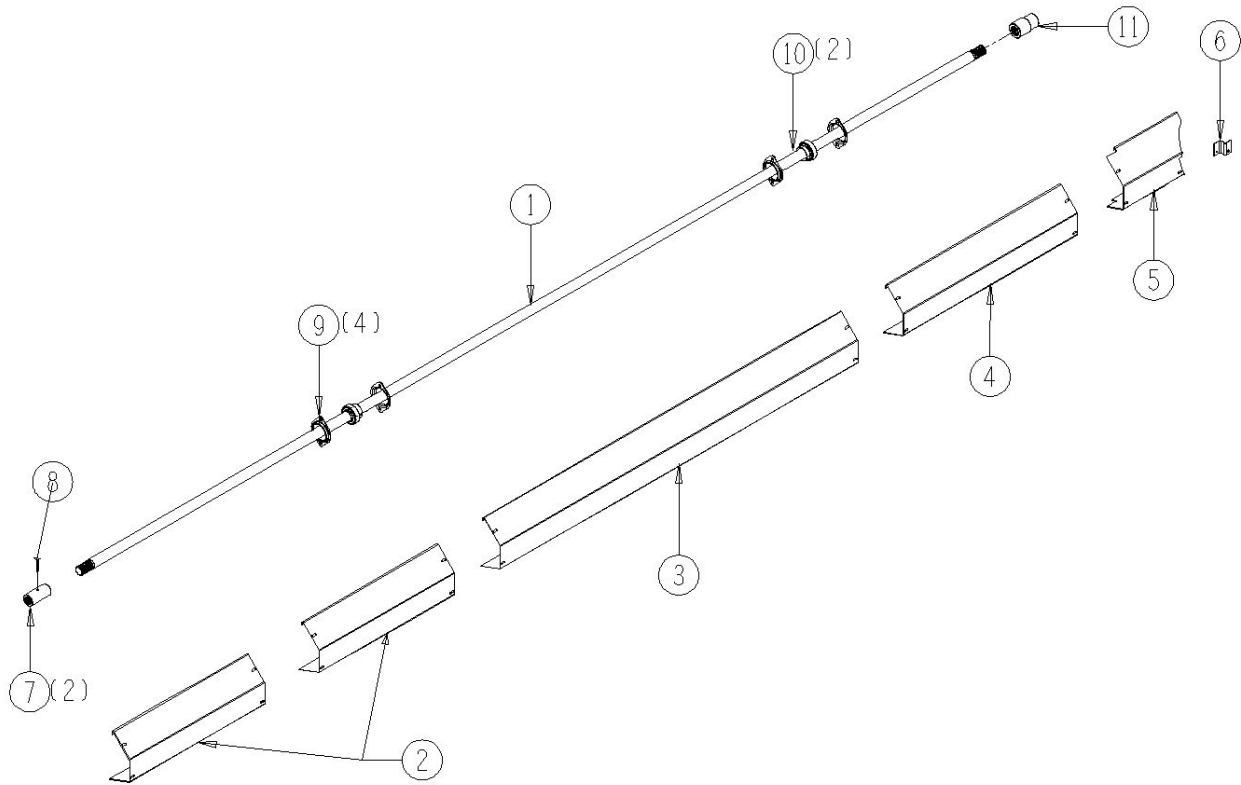

7103-2-6 Gear Case

<u>Ref</u>	<u>Part No.</u>	<u>Description</u>	<u>Parts – Assembly</u>	<u>Will Fit SN</u>	<u>Remarks</u>
1	PR23902	Gearbox for Spreader, 2 Shaft	1		
101	BL-8-225-C	1/2 UNC X 2 1/4 CARRIAGE BOLT GR5 ZINC	4		
102	BL-8-N	1/2-13 HEX FIN NUTS ZC	4		
103	BL-8-LW	1/2 SPLIT LW ZC	4		
104	BL-8-SW	1/2 SAE FW ZC	4		
801	PR23902-A	Double Lip Seal	1		Reference Only, Special Order
802	PR23902-B	Shaft	1		Reference Only, Special Order
803	PR23902-C	Bearing & Race	2		
804	PR23902-D	Spacer	1		Reference Only, Special Order
805	PR23902-E	Snap Ring	1		Reference Only, Special Order
807	PR23902-G	Shim Kit	1		Contains 9 pieces Reference Only, Special Order
808	PR23902-H	Pinion	1		Reference Only, Special Order
809	PR23902-J	Nut	1		Reference Only, Special Order
810	PR23902-K	Double Lip Seal	1		Reference Only, Special Order
811	PR23902-L	Housing	1		Reference Only, Special Order
812	PR23902-M	Dipstick	1		Reference Only, Special Order
813	PR23902-N	Cotter Pin	1		Reference Only, Special Order
814	PR23902-P	Bearing & Race (Output shaft)	2		
815	PR23902-Q	Shim Kit	2		Contains 4 pieces Reference Only, Special Order
816	PR23902-R	Shaft, Output	1		
817	PR23902-S	Bolt M10 x 22	8		Reference Only, Special Order
818	PR23902-T	Cover	1		Reference Only, Special Order
819	PR23902-U	Bevel Gear	1		Reference Only, Special Order

7103-2-6 GEAR CASE

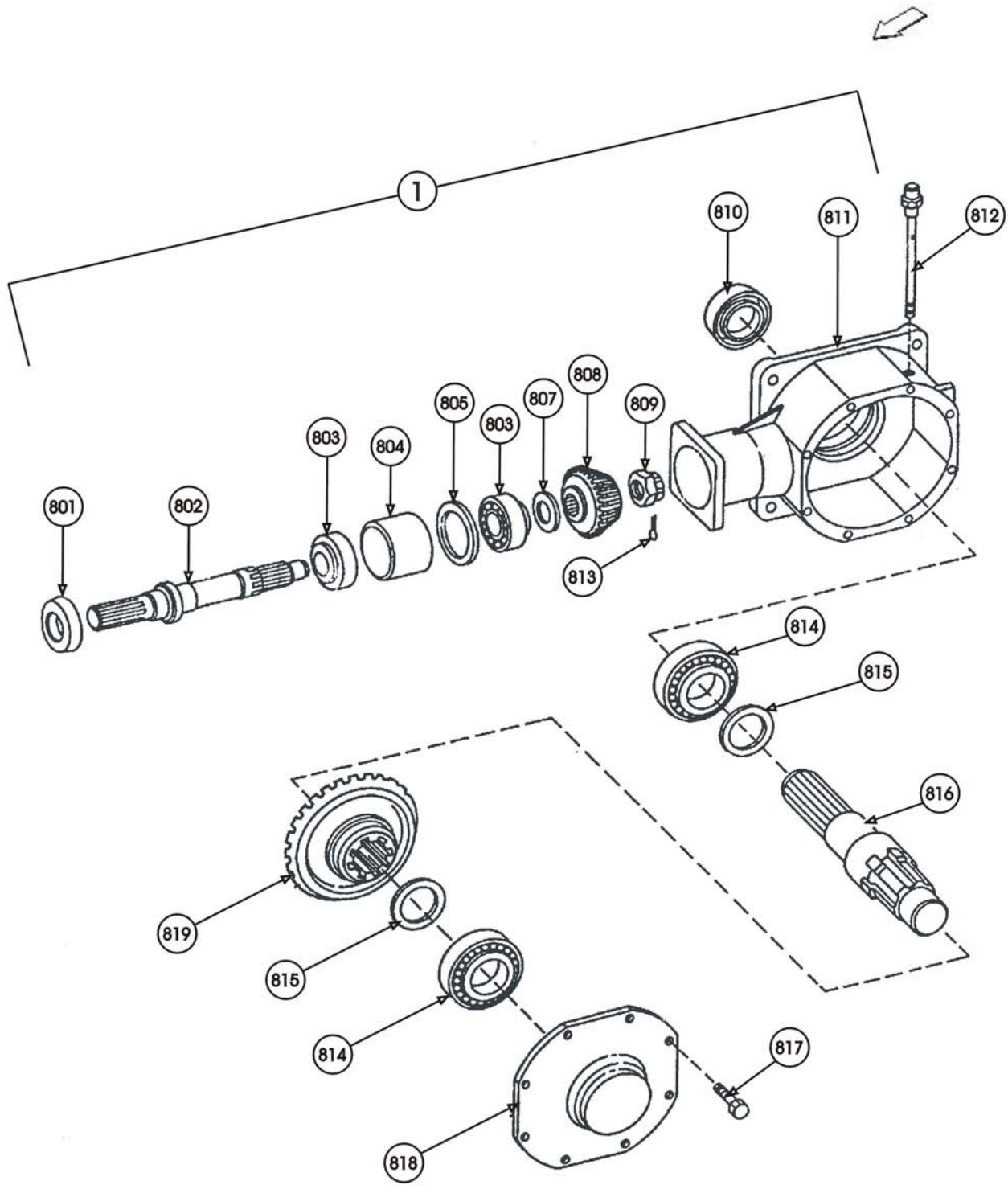

7103-2-7 Main Beater

<u>Ref</u>	<u>Part No.</u>	<u>Description</u>	<u>Parts – Assembly</u>	<u>Will Fit SN</u>	<u>Remarks</u>
1	PR23263	Bottom Beater Wldmt, 790 & 1190	1		
1	PR23270	Bottom Beater Wldmt, 1190	0	71003001- 71004018	
2	PR34754	Shaft, Inside Drum, Bottom Beater, Spreader	0	71003001- 71004018	Alignment hole to be drilled at time of assembly.
3	PR34822	Beater Blade for Spreader, 790 & 1190	16		
4	PR34987	Main Beater Shield	1		
5	PIN-5-40	Roll Pin, 5/16 x 2 1/2	1		
6	BR-175-085-I	Bearing, 1 3/4" ID, TS	1		
7	BR-085-MS	Stamped Bearing Housing for 1 3/4" Bearing	2		
8	AP-12	3/4" NPT Plug	1		
101	BL-8-175-C	1/2 UNC X 1 3/4 CARRIAGE BOLT GR5 ZINC	4		
102	BL-8-150-H	1/2 UNC X 1 1/2 HH C/S BOLT GR5 ZINC	32		
103	BL-8-N	1/2-13 HEX FIN NUTS ZC	4		
104	BL-8-LW	1/2 SPLIT LW ZC	4		
105	BL-8-SW	1/2 SAE FW ZC	68		
106	BL-8-LN	1/2-13 HEX LOCK NUT NYLON INSERT ZC	32		
801	PR34826	Bracket, Paddle, Lower Beater	8		
802	PR34828	Bracket, Paddle, Lower Beater	8		
803	PIN-5-24	Roll Pin, 5/16" x 1 1/2"	2		

7103-2-7 MAIN BEATER

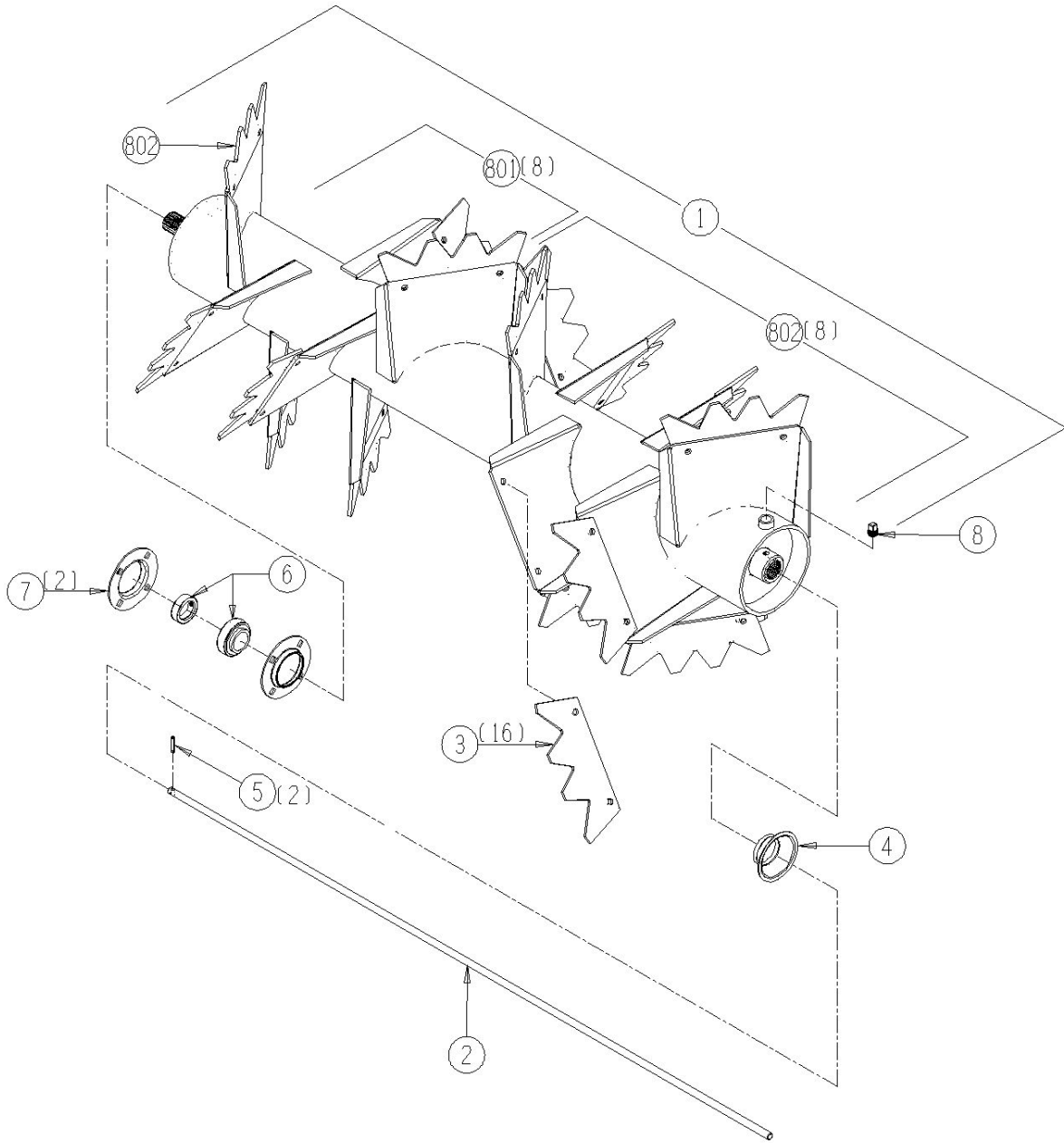

7103-2-8 Interm. Beater

<u>Ref</u>	<u>Part No.</u>	<u>Description</u>	<u>Parts – Assembly</u>	<u>Will Fit SN</u>	<u>Remarks</u>
1	PR39073	Beater, Interm, Splined, 1190	1		
2	BR-085-MS	Stamped Bearing Housing for 1 3/4" Bearing	4		
3	BR-175-085-I	Bearing, 1 3/4" ID, TS	2		
4	PR35336	Bearing Cap, Large	1		
5	PR34822	Beater Blade for Spreader, 790 & 1190	16		
101	BL-8-150-H	1/2 UNC X 1 1/2 HH C/S BOLT GR5 ZINC	32		
102	BL-8-200-C	1/2-13 x 2 CARRIAGE BOLT GR5 ZINC	4		
103	BL-8-650-H	Grade 5 Bolt 1/2 x 6 1/2	2		
104	BL-8-LN	1/2-13 HEX LOCK NUT NYLON INSERT ZC	50		
105	BL-8-LW	1/2 SPLIT LW ZC	16		
106	BL-8-N	1/2-13 HEX FIN NUTS ZC	16		
107	BL-8-SW	1/2 SAE FW ZC	88		
801	PR39072-B	Paddle Bracket	8	PR39072	
802	PR39072-C	Paddle Bracket	8	PR39072	

7103-2-8 INTERM. BEATER

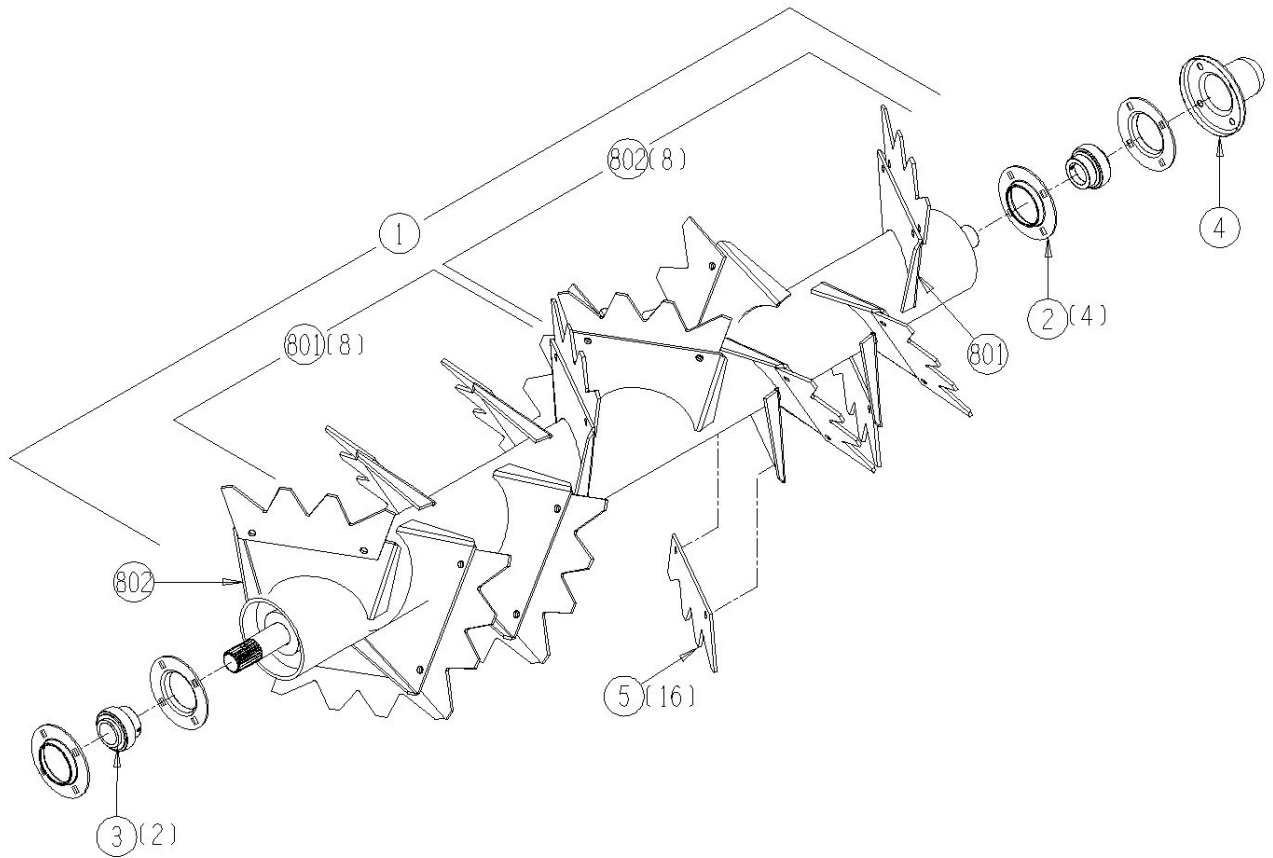

7103-2-8A Interm. Beater, S.N.'s 71003001-71004018

<u>Ref</u>	<u>Part No.</u>	<u>Description</u>	<u>Parts – Assembly</u>	<u>Will Fit SN</u>	<u>Remarks</u>
0	0000	Manufacturing Labor	4		
0	0001	Painting (Includes Paint)	0.5		
1	PR39072	Beater, Interm, 1190	1	71003001- 71004018	
2	BR-072-MSTR	Stamped Bearing Housing for 1 7/16" Bearing, 3 Bolt	4		
3	BR-144-072-I	Bearing, 1 7/16" ID, TS	2		
4	PR28029	Upper Beater Cap	1		
5	PR34822	Beater Blade for Spreader, 790 & 1190	16		
101	BL-8-650-H	Grade 5 Bolt 1/2 x 6 1/2	2		
102	BL-6-100-C	3/8 UNC X 1 CARRIAGE BOLT GR5 ZINC	11		
103	BL-6-150-C	3/8 UNC X 1 1/2 CARRIAGE BOLT GR5 ZINC	3		
104	BL-6-SW	3/8 SAE FW ZC	20		
105	BL-6-N	3/8-16 HEX NUTS ZC	14		
106	BL-6-LW	3/8 SPLIT LW ZC	14		
107	BL-6-LN	3/8 UNC FIN HEX LOCK NUT NE A563 GrA ZINC	3		
108	BL-8-LN	1/2-13 HEX LOCK NUT NYLON INSERT ZC	34		
109	BL-8-150-H	1/2 UNC X 1 1/2 HH C/S BOLT GR5 ZINC	32		
110	BL-8-SW	1/2 SAE FW ZC	64		
801	PR39072-B	Paddle Bracket	8	PR39072	
802	PR39072-C	Paddle Bracket	8	PR39072	

7103-2-8A INTERM. BEATER
S.N.'S 71003001- 71004018

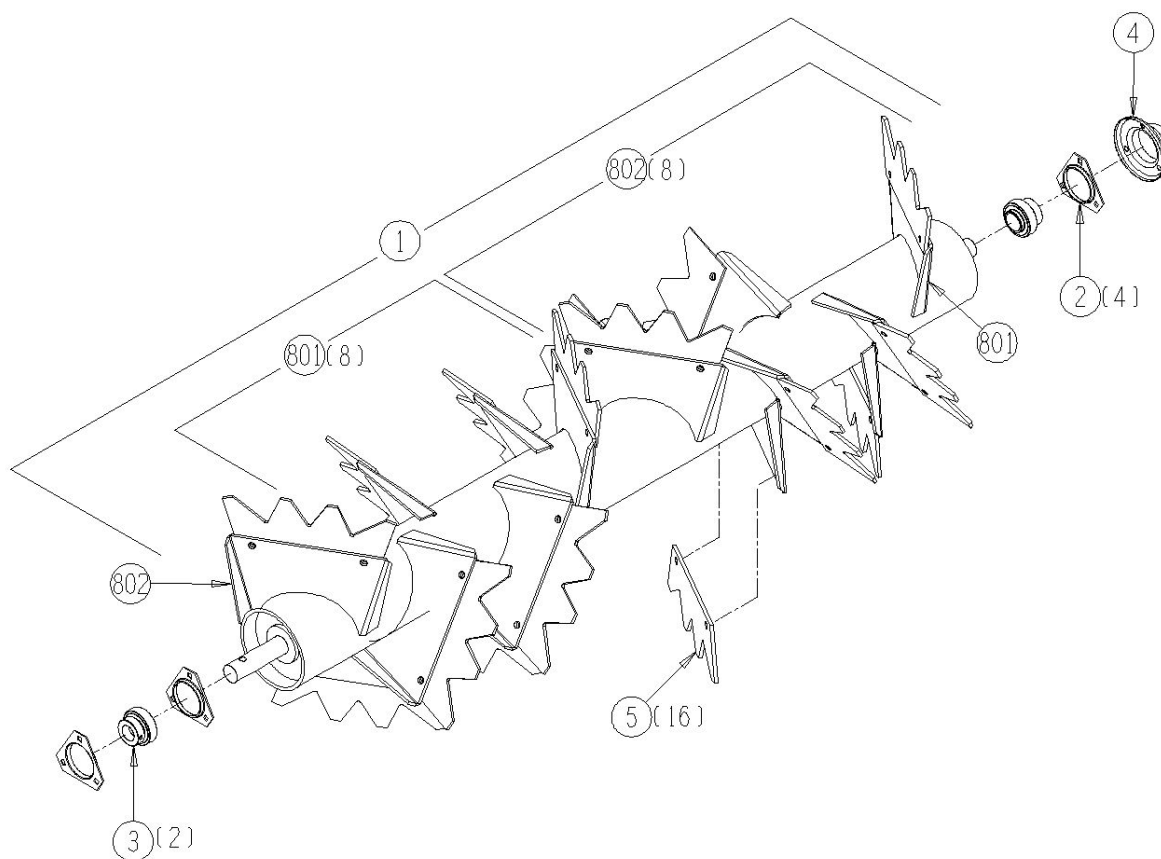

7103-2-9 Interm. Beater Drive - Sprockets & Chain

<u>Ref</u>	<u>Part No.</u>	<u>Description</u>	<u>Parts – Assembly</u>	<u>Will Fit SN</u>	<u>Remarks</u>
1	PR39160	Sprocket, Splined Hub, Main Beater, 14T-80	1		
2	PR39158	Sprocket, Splined Hub, Main Beater, 21T-80	1	Main Beater for 71003001- 71007002 & 71007005	
2	PR39159	Sprocket, Splined Hub, Interm, 19T-80	0	71003001- 71007002 & 71007005	
3	RLT-035-228	Roller 3.5 dia x 2.2 x 1/2" bore, no flange	1		
4	CH-80-79	Roller Chain, 79 pitches, #80, Interm Beater Drive w/master	1		
4	CH-80-81	Roller Chain, 81 pitches, #80, Interm Beater Drive w/master	0	71003001- 71007002 & 71007005	
5	PR23445	Bracket, Chain Slack Adjuster	1		
6	PR23452	Shield, Interm Beater Drive, 1190	1		
7	SPA-0061	Spacer, Spreader	1		
8	LA-1530	Medium Rubber T Latch Assembly	1		
9	PIN-5-36	Roll Pin, 5/16 x 2 1/4	2		
101	RI-3-6-SS	SS Pop Rivets, 3/16 x .251-.375, Buttonhead	17		

7103-2-9 INTERM. BEATER DRIVE
SPROCKETS & CHAIN

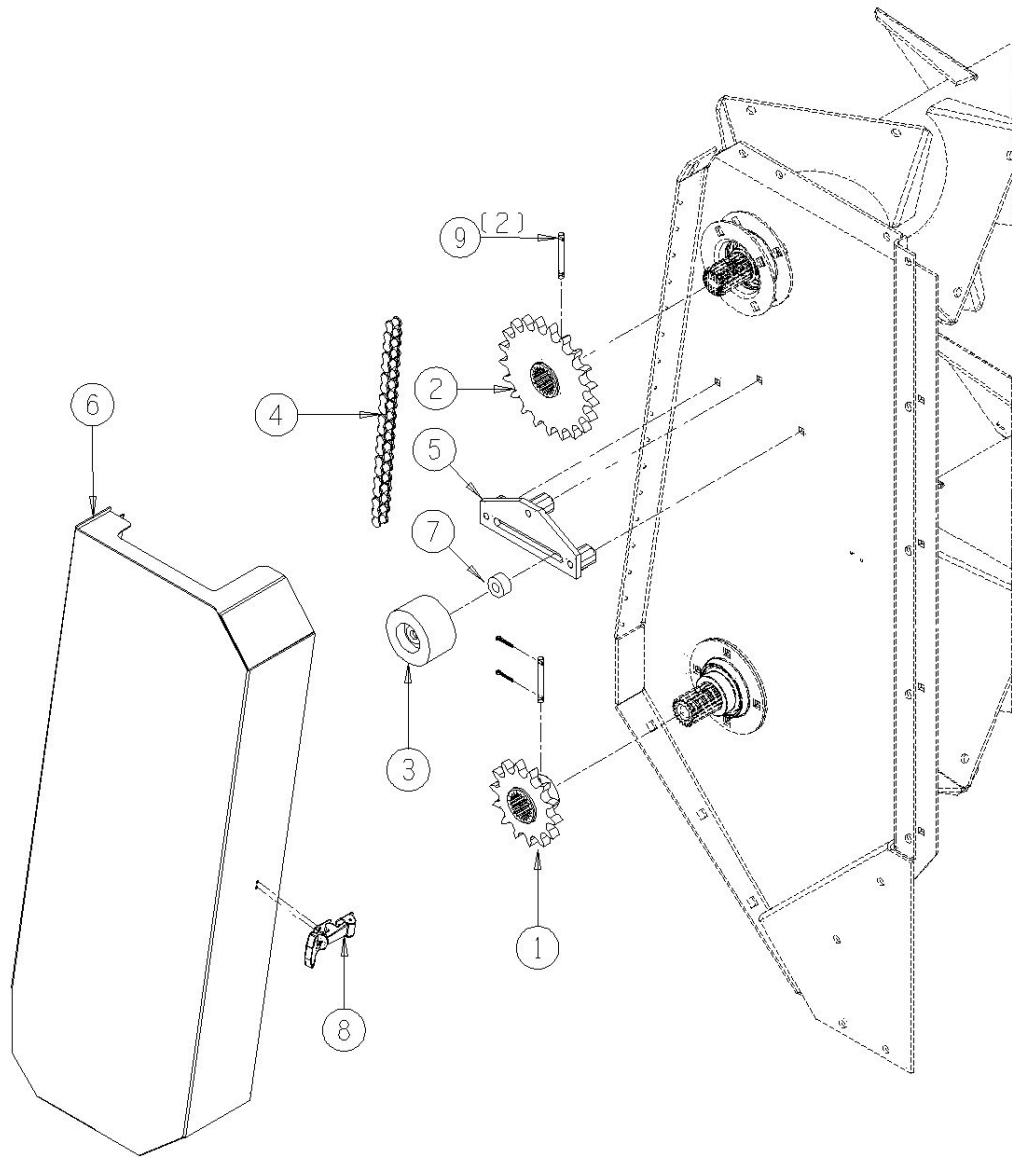

7103-2-9A Interm. Beater Drive, S.N.'s 71003001-71004018

<u>Ref</u>	<u>Part No.</u>	<u>Description</u>	<u>Parts – Assembly</u>	<u>Will Fit SN</u>	<u>Remarks</u>
1	PR39153	Sprocket, Splined Hub, #60-21 Tooth	1		
1	SP-60SDS21	#60 Sprocket, 21 Teeth, SDS Bushing, Hardened Teeth	1		
2	PU-SDS-28	Bushing, SDS x 1 3/4"	1		
3	RLT-035-228	Roller 3.5 dia x 2.2 x 1/2" bore, no flange	1		
4	CH-60H-105	Roller Chain 105 pitches #60H Interm Beater Drive w/master	1		Converted existing inventory to CH-60H-95. Consider upgrading with KIT-0165.
5	PR23445	Bracket, Chain Slack Adjuster	1		
6	PR23452	Shield, Interm Beater Drive, 1190	1		
8	PR39085	Sprocket Wldmt, Upper Beater, Spreader	1		
8	PR39154	Sprocket, Splined Hub, 24 Tooth	1		
9	LA-1530	Medium Rubber T Latch Assembly	1		
10	PIN-5-36	Roll Pin, 5/16 x 2 1/4	2		
101	RI-3-6-SS	SS Pop Rivets, 3/16 x .251-.375, Buttonhead	17		

7103-2-9A
INTERM. BEATER DRIVE, S.N.'S 71003001-71004018

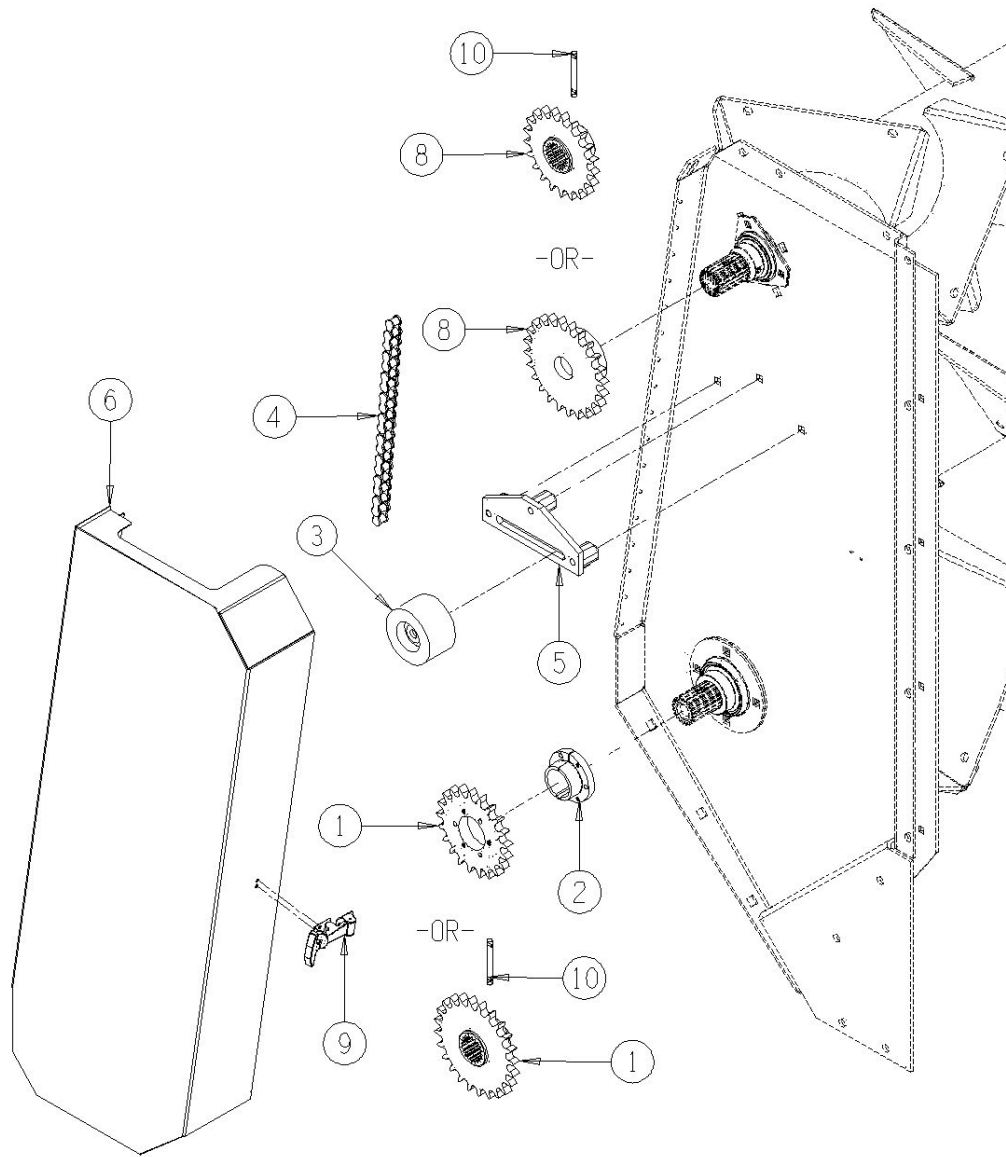

7103-2-10 Upper Beater

<u>Ref</u>	<u>Part No.</u>	<u>Description</u>	<u>Parts – Assembly</u>	<u>Will Fit SN</u>	<u>Remarks</u>
1	PR39075	Beater, Upper, 1190	0	71003001- 71004018	
1	PR39076	Beater, Upper, 1190	1		
2	PR23447	Upper Beater Support, LH	1		
3	PR23448	Shield, Upper Beater, LH	1		
4	PR23446	Upper Beater Support, RH	1		
5	PR23449	Shield, Upper Beater, RH	1		
6	PR23444	Cover, Upper Beater Drive	1		
8	BR-072-MSTR	Stamped Bearing Housing for 1 7/16" Bearing, 3 Bolt	4		
9	BR-144-072-I	Bearing, 1 7/16" ID, TS	2		
10	LA-1530	Medium Rubber T Latch Assembly	1		

7103-2-10 OPTIONAL UPPER BEATER

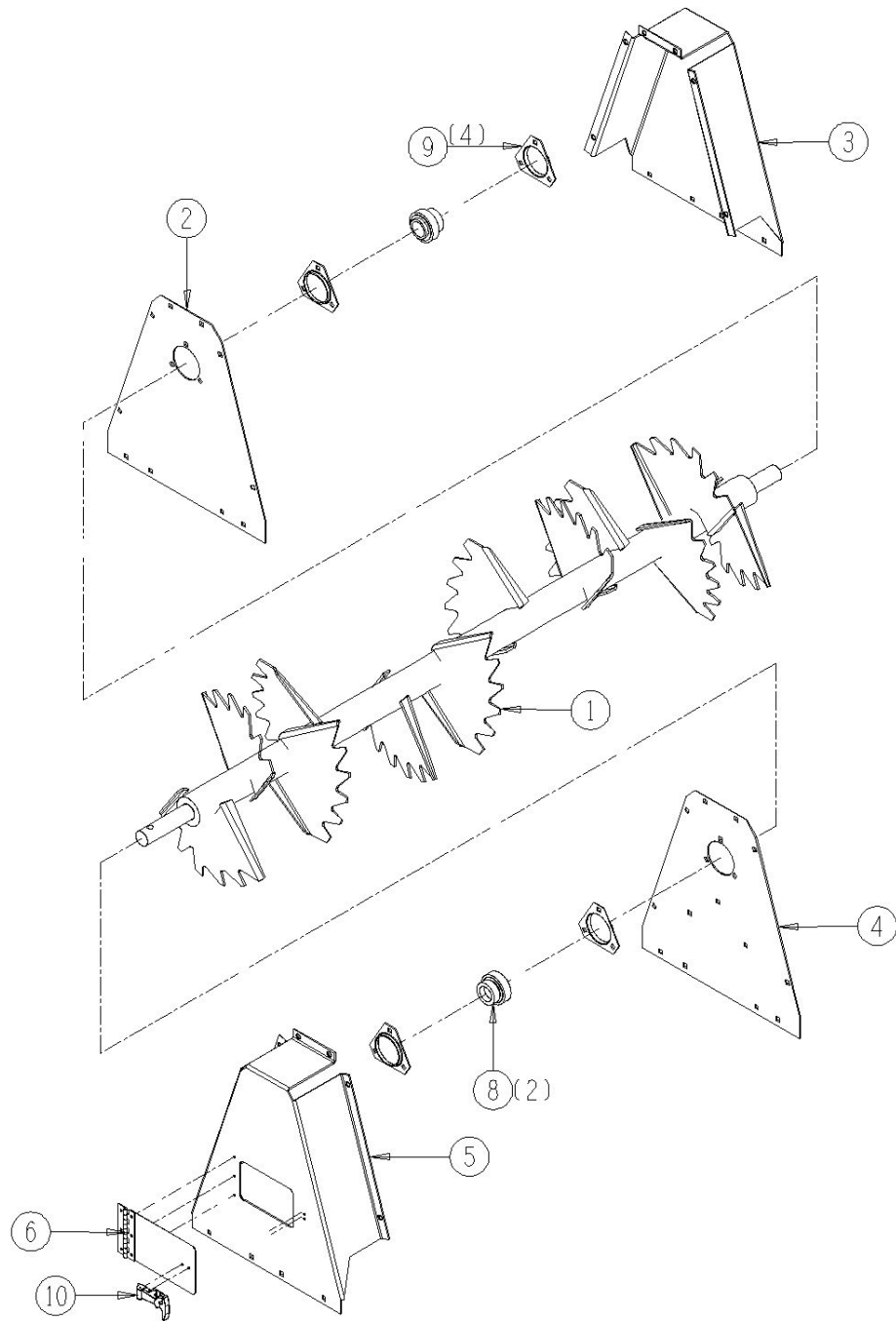

7103-2-11 Upper Beater Drive - Sprockets & Chain

<u>Ref</u>	<u>Part No.</u>	<u>Description</u>	<u>Parts – Assembly</u>	<u>Will Fit SN</u>	<u>Remarks</u>
1	PR39088	Sprocket, Dbl, 24T	0	71003001- 71004018	
1	PR39152	Sprocket, Double, Splined, 80/60	0	71003001- 71007002 & 71007005	
1	PR39155	Sprocket, Double, Splined Hub, 24 Tooth	0		
1	PR39162	Sprocket, Double, Splined, 80/60	1		
2	PR23442	Bracket, Slack Adjuster	1		
2	PR23443	Bracket, Slack Adjuster	0	71003001- 71004018	
3	RLT-035-228	Roller 3.5 dia x 2.2 x 1/2" bore, no flange	1		
4	PR39085	Sprocket Wldmt, Upper Beater, Spreader	1		
5	CH-60H-81	Roller Chain 81 pitches #60H	1		

7103-2-11 OPTIONAL UPPER BEATER DRIVE

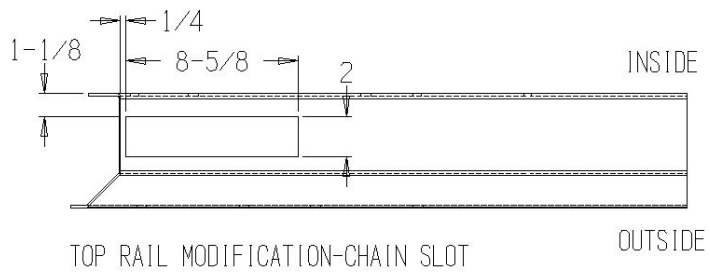
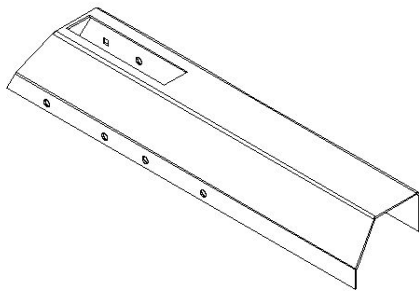
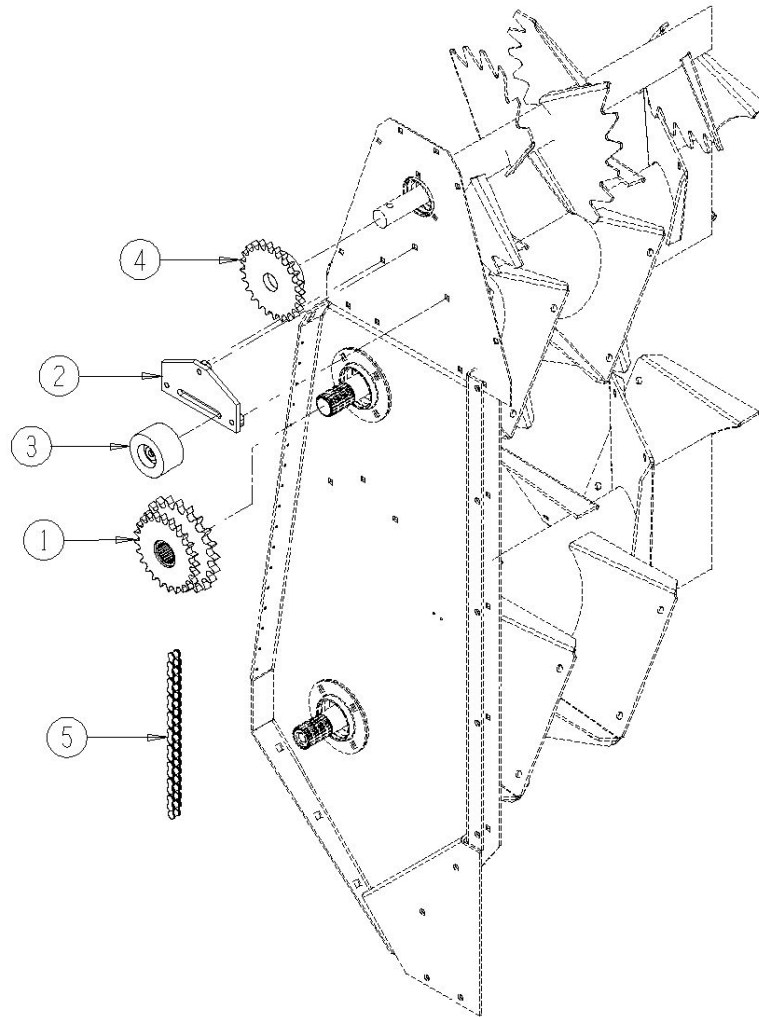

7103-3-1 Hydraulics, Main

<u>Ref</u>	<u>Part No.</u>	<u>Description</u>	<u>Parts – Assembly</u>	<u>Will Fit SN</u>	<u>Remarks</u>
1	A-6500-10	Elbow, 5/8" MJ x 5/8" FJX	1		
2	A-6801-L-10	Elbow, Long, 5/8" MJ x 10 SAE	5		
3	A-6801-10	Elbow, 5/8" MJ x 10 SAE	1		
4	H-T7001	Hyd Tube, Primary/Sec Cylinder, 5/8" Dia.	3		
5	A-2500-10	Elbow, 5/8" MJ x 5/8" MJ	1		
6	H-T7002	Hyd Tube, Primary to Sec. Cylinder, 5/8" dia.	2		
7	H8-40-10MJ-10MJ	1/2" hose 5/8" MJ x 5/8" MJ x 39.75" long	2		
8	H-T7003	Hyd Tube, Primary Cylinder, Rear, 5/8" dia.	1		
9	A-2403-10	Union, 5/8" MJ x 5/8" MJ	1		
10	H-T7004	Hyd Tube, Primary Cylinder to Supply, 5/8" dia.	1		
11	H-T7005	Hyd Tube, Supply To Primary Cylinder, 5/8" dia	1		
12	H8-75-8MP-10FJ	1/2" hose 1/2" MP x 5/8" FJ x 75" long	2		
13	A-306-10	Lock Nut, Bulkhead, For 5/8" MJIC	2		
14	A-2701-10	Elbow, Bulkhead, 5/8" MJ x 5/8" MJ	2		
15	A-QD2010-8-8	Tractor Quick Coupler, Male, 1/2" w/ FPT	2		
16	PR34897	Hose Clamp, 1/2" Hydraulic, 13/16" O.D. Hose	1		
17	HW-10	5/8" OD Washer for Hydraulic Tube/Hose	16		
18	PR34893	Support, Clamp, 1/2" Double Hose Clamp	1		
101	BL-6-200-C	3/8 UNC X 2 CARRIAGE BOLT GR5 ZINC	1		
102	BL-6-N	3/8-16 HEX NUTS ZC	1		
103	BL-6-LW	3/8 SPLIT LW ZC	1		
104	BL-6-SW	3/8 SAE FW ZC	1		
601	HY-TRAN	Hytran @ gal	5		
602	HP-1038	Gear Lube, 80W90 @ Quart	1.25	Hydra Ram Spreader	

7103-3-1 HYDRAULICS, CONTROL VALVE
TO PUSH OFF CYLINDERS

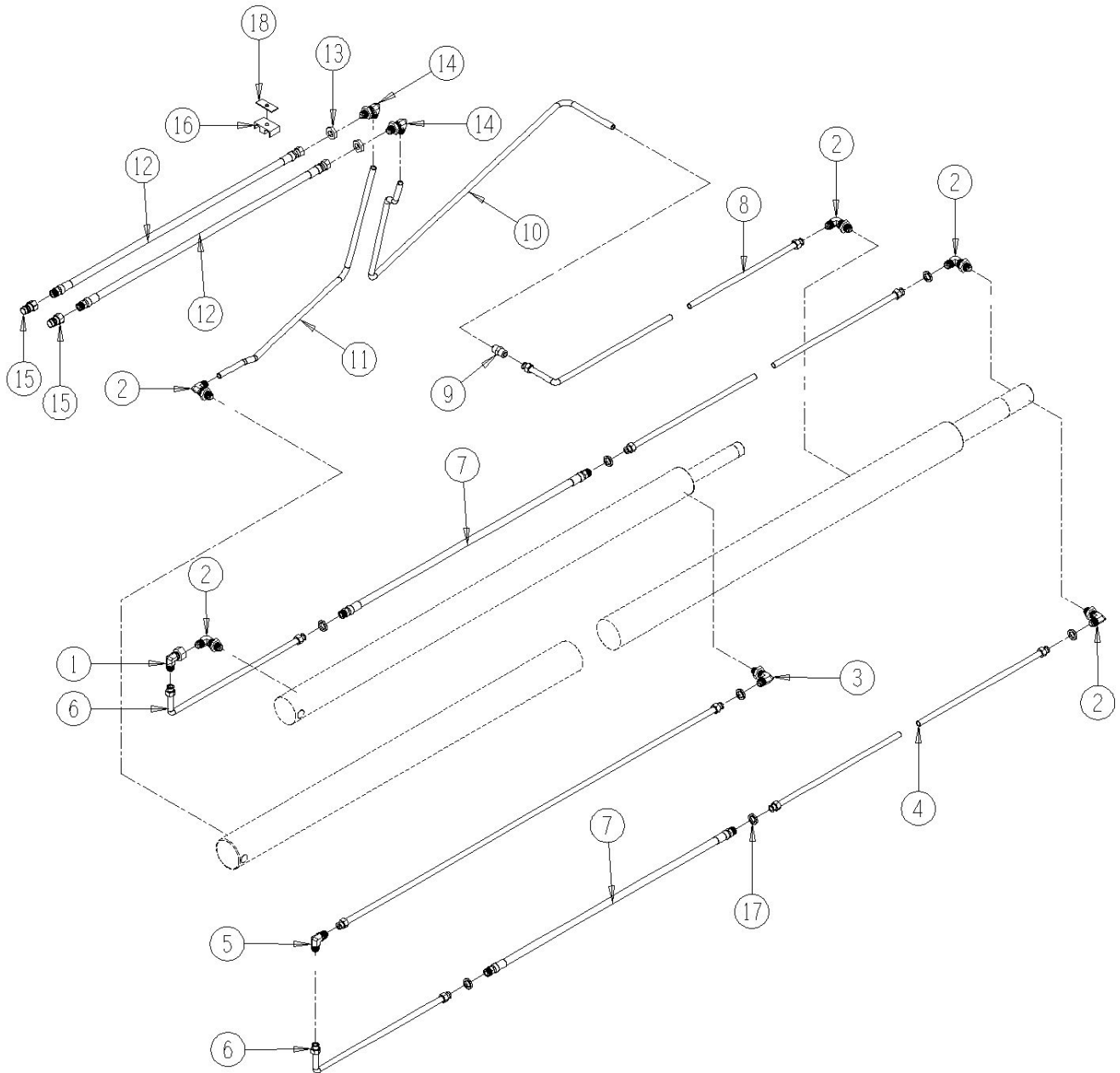

7103-3-2 Hydraulics, Endgate

<u>Ref</u>	<u>Part No.</u>	<u>Description</u>	<u>Parts – Assembly</u>	<u>Will Fit SN</u>	<u>Remarks</u>
1	A-6801-6	Elbow, 3/8" MJ x 6 SAE	4		
2	A-2603-6	Tee, 3/8" MJ x 3/8" MJ x 3/8" MJ	2		
3	HW-06	3/8" OD Washer for Hydraulic Tube/Hose	4		
4	A-306-6	Lock Nut, Bulkhead, For 3/8" MJIC	2		
5	H4-75-6FJ-8MP	1/4" hose 3/8" FJ x 1/2" MP x 75" long	2		
6	A-2700-6	Union, Bulkhead, 3/8" MJ x 3/8" MJ	2		
7	H-T7006	Hyd Tube, Endgate, Front, 3/8" dia.	2		
7	H-T7008	Hyd Tube, Endgate, Front, 3/8" dia., 1190	0	71003001- 71007002 & 71007005	
8	H4-230-6FJ-6FJ	1/4" hose 3/8" FJ x 3/8" FJ x 230" long	0	71003001- 71007002 & 71007005	
8	H4-232-6FJ-6FJ	1/4" hose 3/8" FJ x 3/8" FJ x 232" long	4		
9	H4-208-6FJ-6FJ	1/4" hose 3/8" FJ x 3/8" FJ x 208" long	0	71003001- 71007002 & 71007005	
15	A-QD2010-8-8	Tractor Quick Coupler, Male, 1/2" w/ FPT	2		
16	PR34896	Hose Clamp, 1/4" Hydraulic, 1/2" O.D. Hose	11		
17	WT-17H	Heavy Duty Wire Tie 17.5"	6		
18	ELL-12	3/4" OD Black Spiral Wrap @ Foot	2.7		
19	PR34894	Support, Clamp, 1/4" Double Hose Clamp	9		
101	BL-6-200-C	3/8 UNC X 2 CARRIAGE BOLT GR5 ZINC	1		
102	BL-6-N	3/8-16 HEX NUTS ZC	1		
103	BL-6-LW	3/8 SPLIT LW ZC	1		
104	BL-6-SW	3/8 SAE FW ZC	1		

7103-3-2
HYDRAULICS, TRACTOR TO ENDGATE CYLINDERS

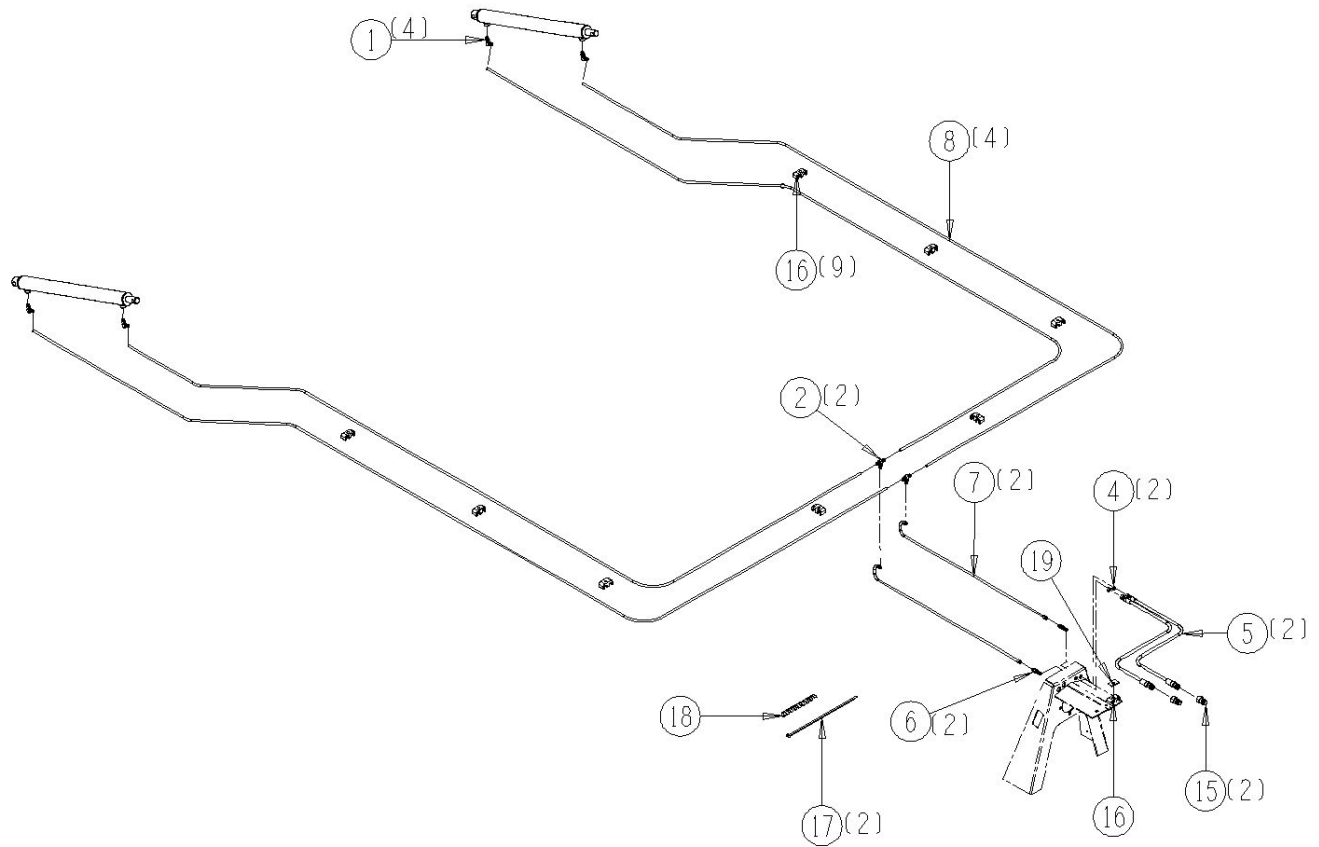

7103-3-3 Main Cylinder

<u>Ref</u>	<u>Part No.</u>	<u>Description</u>	<u>Parts – Assembly</u>	<u>Will Fit SN</u>	<u>Remarks</u>
1	PR23131	Main Cylinder	1		
801	PR23131-L	Barrel Assy.	1		Reference Only, Special Order
802	PR23131-M	Locknut - Thin	1		Reference Only, Special Order
803	PR23131-N	Back Up Washer	2		Reference Only, Special Order
804	PR23131-O	O Ring	1		Part of Seal Kit, Not Sold Separately
805	PR23131-P	Wear Ring	1		Part of Seal Kit, Not Sold Separately
806	PR23131-Q	Piston	1		Reference Only, Special Order
807	PR23131-R	Piston	1		Reference Only, Special Order
808	PR23131-A	Piston Ring	1		Reference Only, Special Order
809	PR23131-B	O-Ring	1		Part of Seal Kit, Not Sold Separately
810	PR23131-C	O-Ring	1		Part of Seal Kit, Not Sold Separately
811	PR23131-D	Back-up Washer	2		Part of Seal Kit, Not Sold Separately
812	PR23131-E	O Ring	1		Part of Seal Kit, Not Sold Separately
813	PR23131-F	Backup Washer	1		Part of Seal Kit, Not Sold Separately
814	PR23131-LR	Lock Ring	1		Reference Only, Special Order
815	PR23131-G	Bearing Assembly	1		Reference Only, Special Order
816	PR23131-H	Transfer Tube	1		Reference Only, Special Order
817	PR23131-I	Bearing Seal	1		Part of Seal Kit, Not Sold Separately
818	PR23131-J	Wiper	1		Part of Seal Kit, Not Sold Separately
819	PR23131-K	Piston Rod Assy. w/ Transfer Tube	1		Reference Only, Special Order Sold only with PR23131-H Transfer Tube
820	PR23131-SK	Seal Kit, Main Cylinder, Per Each	1		

7103-3-3 MAIN CYLINDER, SLIDING FLOOR

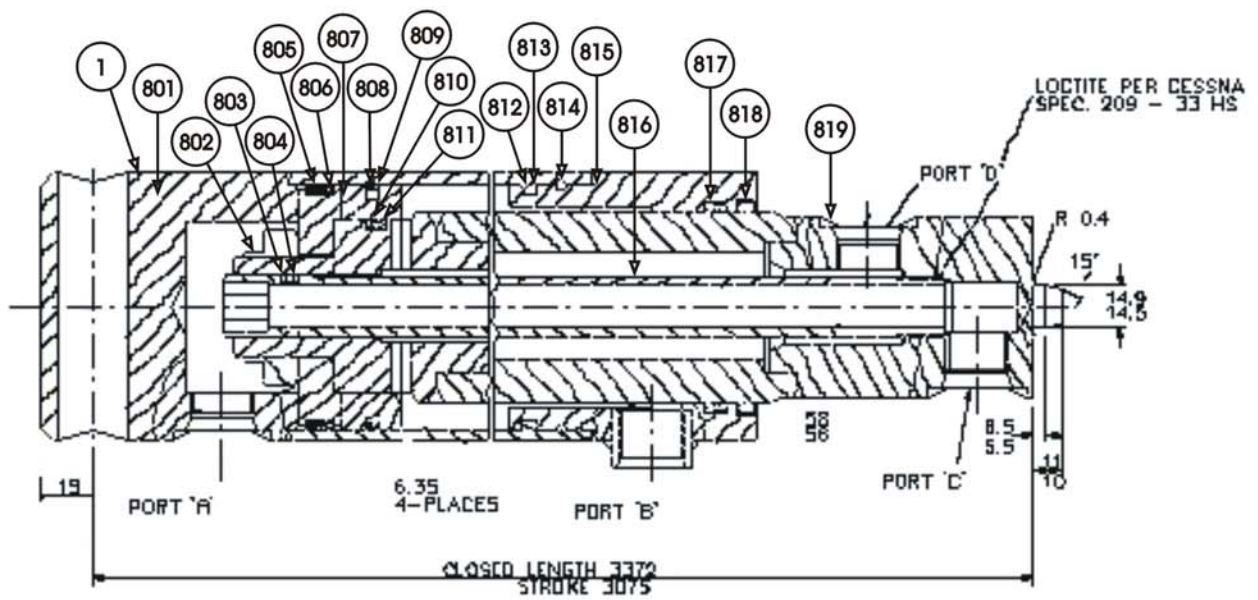

802 Seal Kit

7103-3-4 Secondary Cylinder

<u>Ref</u>	<u>Part No.</u>	<u>Description</u>	<u>Parts – Assembly</u>	<u>Will Fit SN</u>	<u>Remarks</u>
1	PR23143	Secondary Cylinder	1		
801	PR23143-M	1" BSF Nut	1		Reference Only, Special Order
802	PR23143-L	P/Head	1		Reference Only, Special Order
803	PR23143-A	P/Seal	1		Part of Seal Kit, Not Sold Separately
804	PR23143-B	O-Ring	1		Part of Seal Kit, Not Sold Separately
805	PR23143-C	Rod Seal	1		Part of Seal Kit, Not Sold Separately
806	PR23143-I	Cylinder Assy	1		Reference Only, Special Order
807	PR23143-J	P/Rod	1		Reference Only, Special Order
808	PR23143-D	O-Ring	1		Part of Seal Kit, Not Sold Separately
809	PR23143-E	Back Up Ring	1		Part of Seal Kit, Not Sold Separately
810	PR23143-H	Lock Ring	1		Part of Seal Kit, Not Sold Separately
811	PR23143-K	Gland Bearing	1		Reference Only, Special Order
812	PR23143-F	Rod Seal	1		Part of Seal Kit, Not Sold Separately
813	PR23143-G	Wiper	1		Part of Seal Kit, Not Sold Separately
814	PR23143-SK	Seal Kit, Secondary Cylinder, Per Each	1		

7103-3-4 SECONDARY CYLINDER, MOVING PANEL

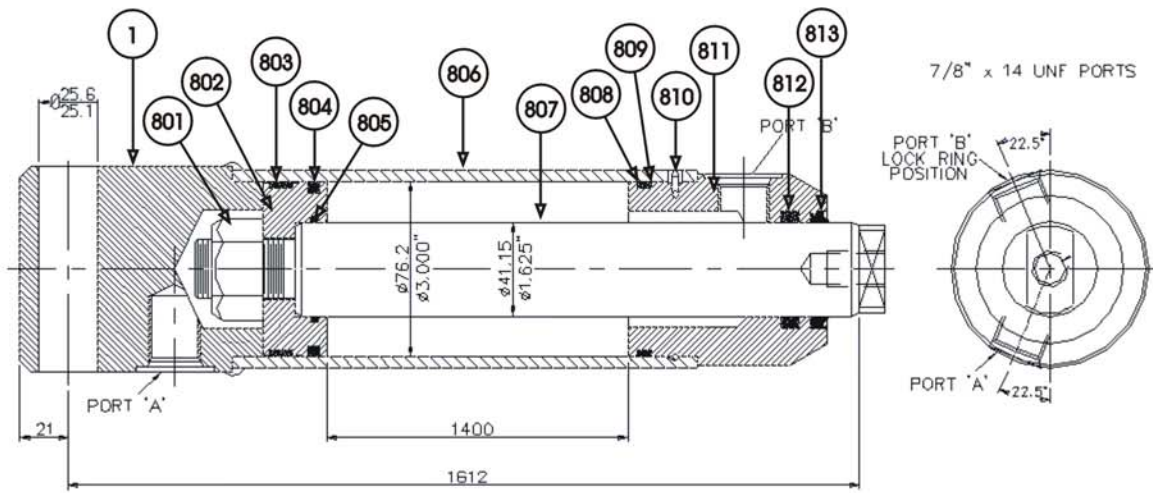

814 Seal Kit

7103-3-5 Endgate Cylinder

<u>Ref</u>	<u>Part No.</u>	<u>Description</u>	<u>Parts – Assembly</u>	<u>Will Fit SN</u>	<u>Remarks</u>
1	PR39069	Cylinder, Endgate, 2.0 bore	2		
801	PR39069A	Internal Cylinder Head 2" (coarse)	1	Verify Stamp Location	
801	PR39069AB	Internal Cylinder Head 2" (fine)	1	Verify Stamp Location	
802	PR39069B	Rod	1		
803	PR39069C	Barrel Assembly	1		
804	PR39069D	Piston	1		
805	PR39069E	Locknut	1		
806	PR39069F	Rod Wiper	1		
807	PR39069G	Loaded U-Cup	1		
808	PR39069H	Wear Ring	1		
809	PR39069I	Back-up Ring	1		
810	PR39069J	O'Ring	1		
811	PR39069K	O'Ring	1		
812	PR39069L	O'Ring	1		
813	PR39069M	Poly Hone	1		
814	PR39069N	Wear Ring	1		

7103-3-5 ENDGATE LIFT CYLINDER

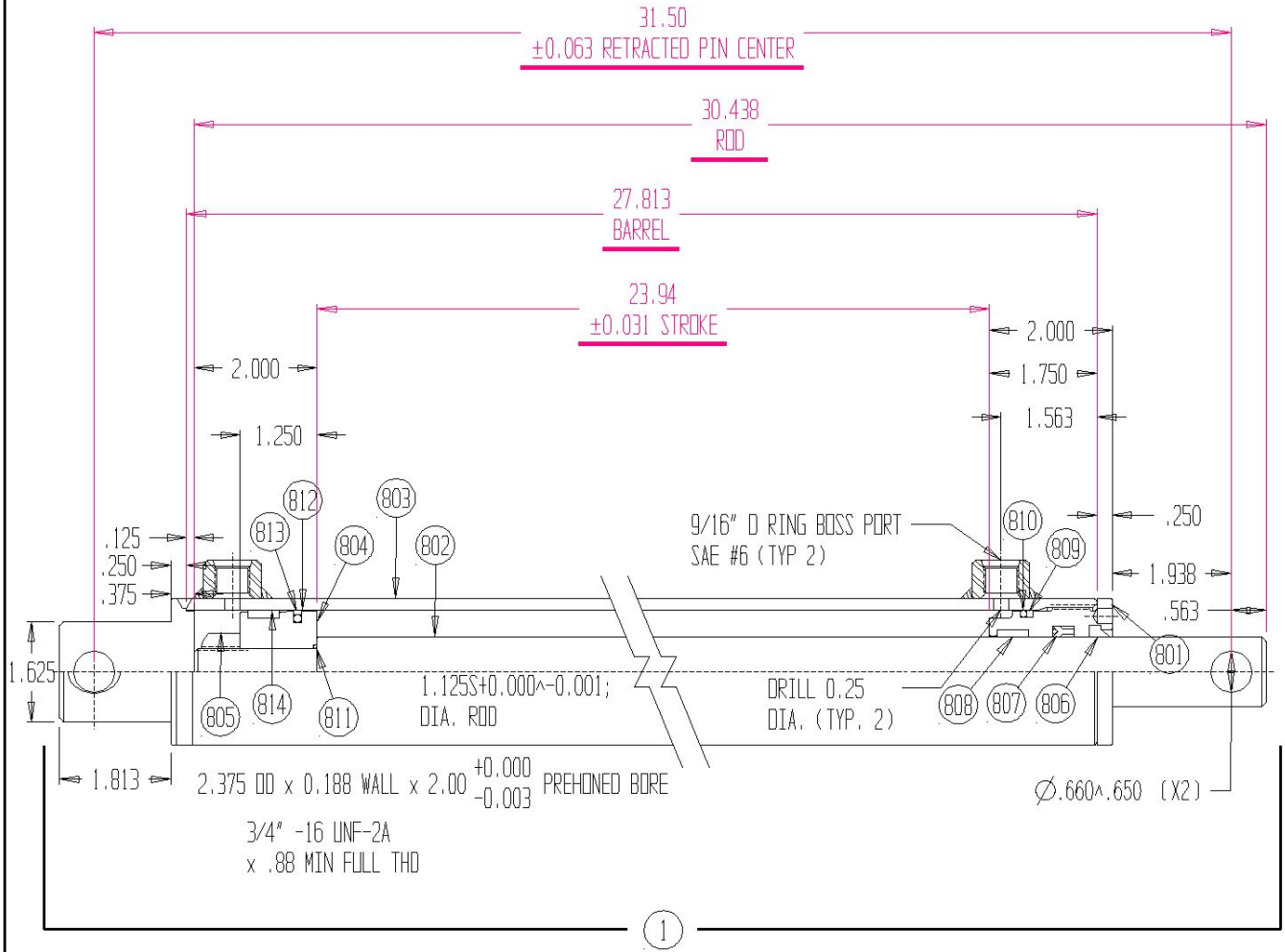

7103-3-6 Optional Control Valve, Closed Center Hydraulic System

<u>Ref</u>	<u>Part No.</u>	<u>Description</u>	<u>Parts – Assembly</u>	<u>Will Fit SN</u>	<u>Remarks</u>
1	HV-8-8M-RFF	Flow Control Valve w/ reverse free flow/closed center	1		
2	A-1501-8-8	1/2 MP x 1/2 FPX90°	2		
3	MOU-0015	Mount, Control Valve, Closed Center, Spreader	1		
4	MOU-0016	Mount, Mating Plate, Control Valve, Closed Center	1		
5	H8-70-8MP-8MP	1/2 in hose 1/2MP x 1/2MP x 70 in long	2		
6	A-QD2010-8-8	Tractor Quick Coupler, Male, 1/2" w/ FPT	1		
7	A-QD2050-8-8	Tractor Quick Coupler, Female, 1/2" w/ FPT	1		
101	BL-4-275-H	1/4-20 X 2 3/4 HEX CAP G5 ZC	4		
102	BL-4-LN	1/4-20 HEX LN NE ZC	6		
103	BL-6-FW	3/8 USS FW ZC	6		
104	BL-4-175-H	1/4-20 X 1 3/4 HEX CAP G5 ZC	2		

7103-3-6
OPTIONAL CONTROL VALVE, CLOSED CENTER HYDRAULIC SYSTEM

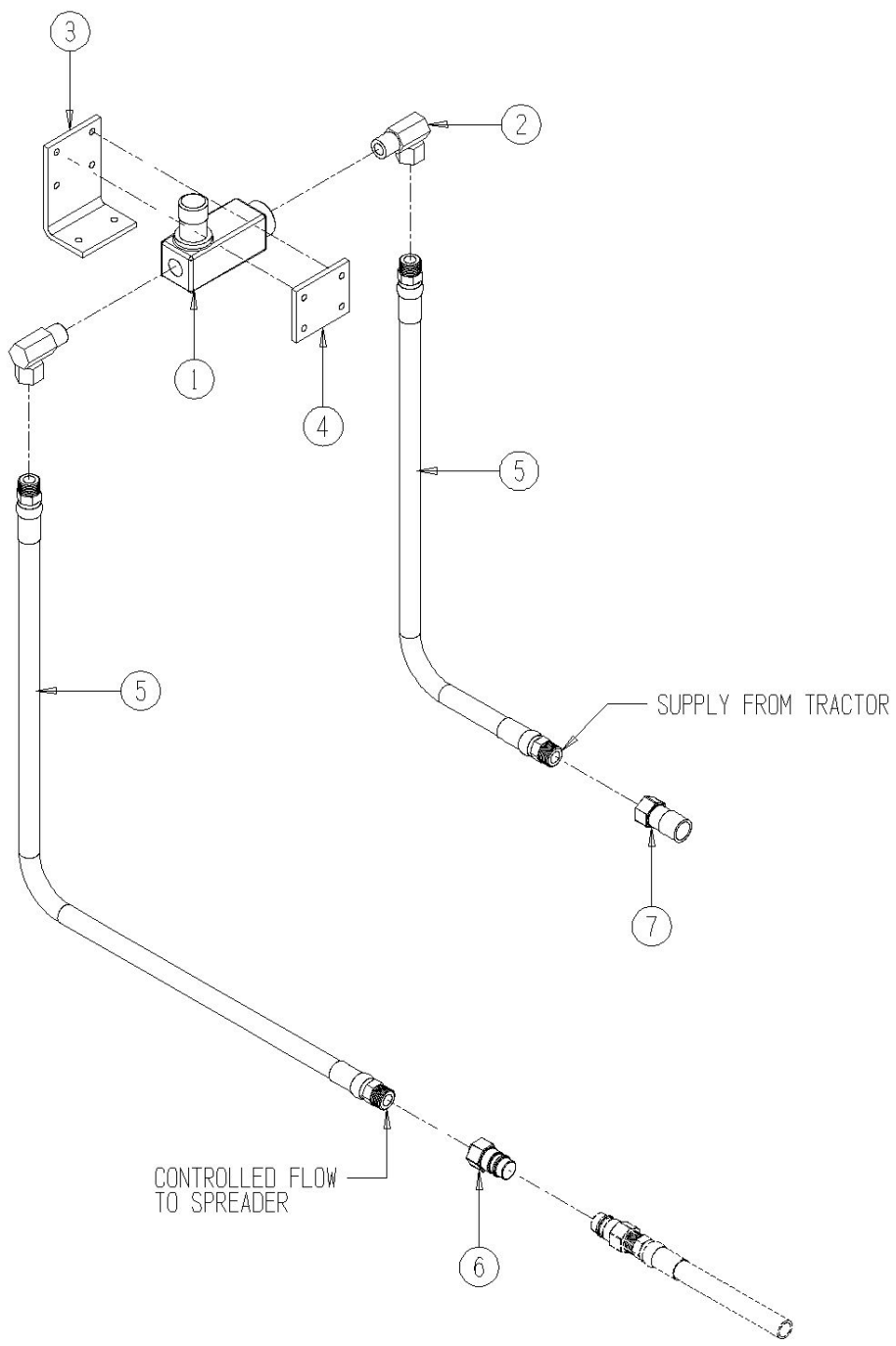

7103-3-7 Optional Control Valve, Open Center Hydraulic System

<u>Ref</u>	<u>Part No.</u>	<u>Description</u>	<u>Parts – Assembly</u>	<u>Will Fit SN</u>	<u>Remarks</u>
1	HV-FC5510	Flow Control	1		
2	A-1601-8-8-8	1/2 MP x 1/2 FPX x 1/2 FPX Tee	1		
3	A-1501-8-8	1/2 MP x 1/2 FPX90°	2		
4	A-6901-10-8	10 SAE x 1/2 FPX90°, Forged	2		
5	A-QD2050-8-8	Tractor Quick Coupler, Female, 1/2" w/ FPT	2		
6	A-QD2010-8-8	Tractor Quick Coupler, Male, 1/2" w/ FPT	2		
7	H8-70-8MP-8MP	1/2 in hose 1/2MP x 1/2MP x 70 in long	4		
8	MOU-0014	Mount, Control Valve, Open Center, Spreader	1		
9	HV-CKV-800S	1/2" Parker Check Valve	1		
10	A-6401-10-8	10 SAE x 1/2 MPT Male	1		
101	BL-4-175-H	1/4-20 X 1 3/4 HEX CAP G5 ZC	4		
102	BL-4-LN	1/4-20 HEX LN NE ZC	4		
103	BL-4-FW	1/4 USS FW ZC	4		

7103-3-7
OPTIONAL CONTROL VALVE, OPEN CENTER HYDRAULIC SYSTEM

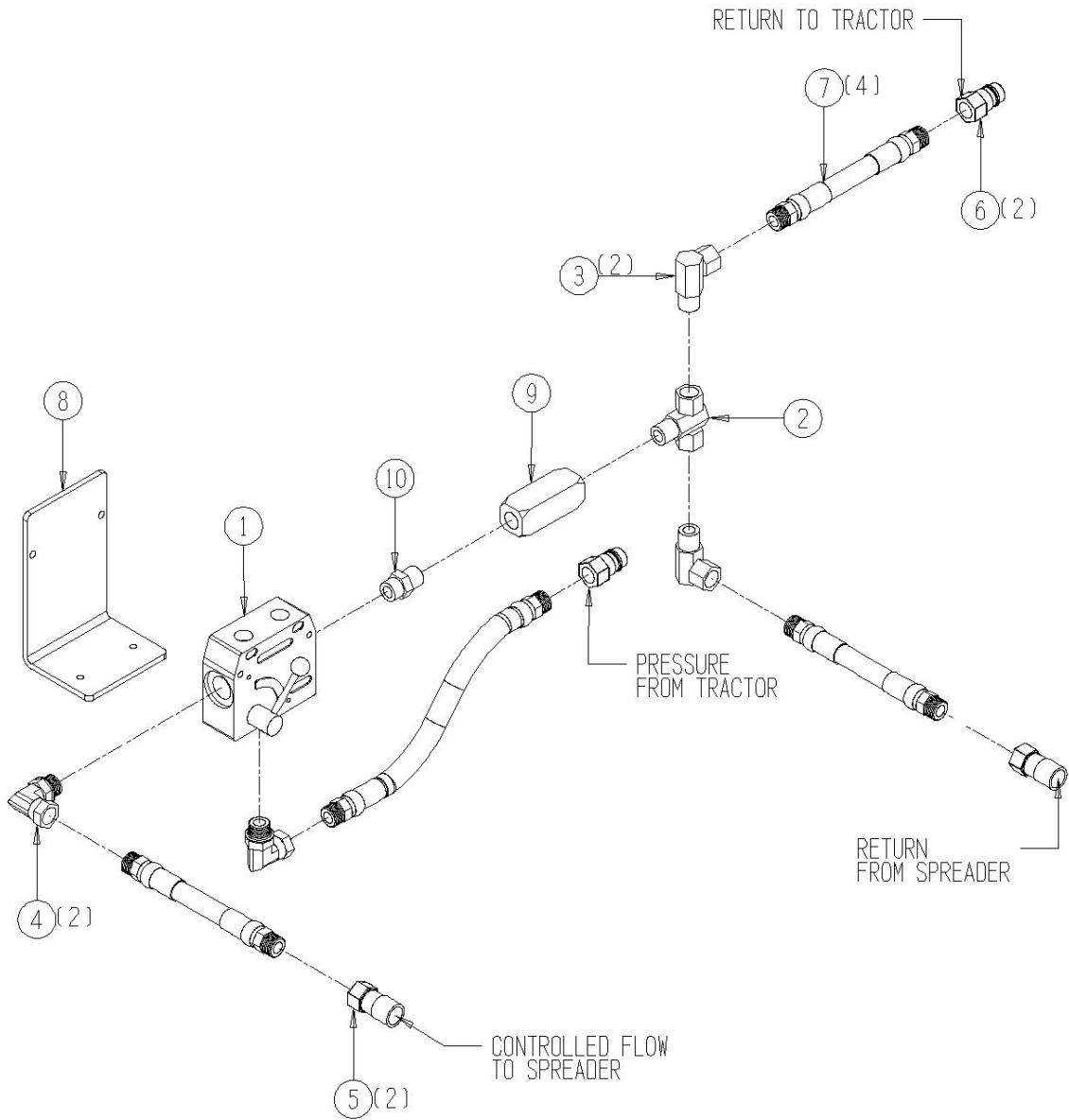

7103-4-2 Safety Tow Chain

<u>Ref</u>	<u>Part No.</u>	<u>Description</u>	<u>Parts – Assembly</u>	<u>Will Fit SN</u>	<u>Remarks</u>
1	FRM-3165	Safety Chain, Agricultural, 40,500 lb. Capacity	1		
101	BL-24-FW	1 1/2" Flat Washer, Zinc	1		
102	BL-16-FW	1" Flat Washer, Zinc	2		
103	BL-16-500-H	1 UNC x 5 HH C/S GR5 ZINC	1		
104	BL-16-LN	1" Lock Nuts w/ Nylon Inserts	1		

7103-4-2
SAFETY TOW CHAIN

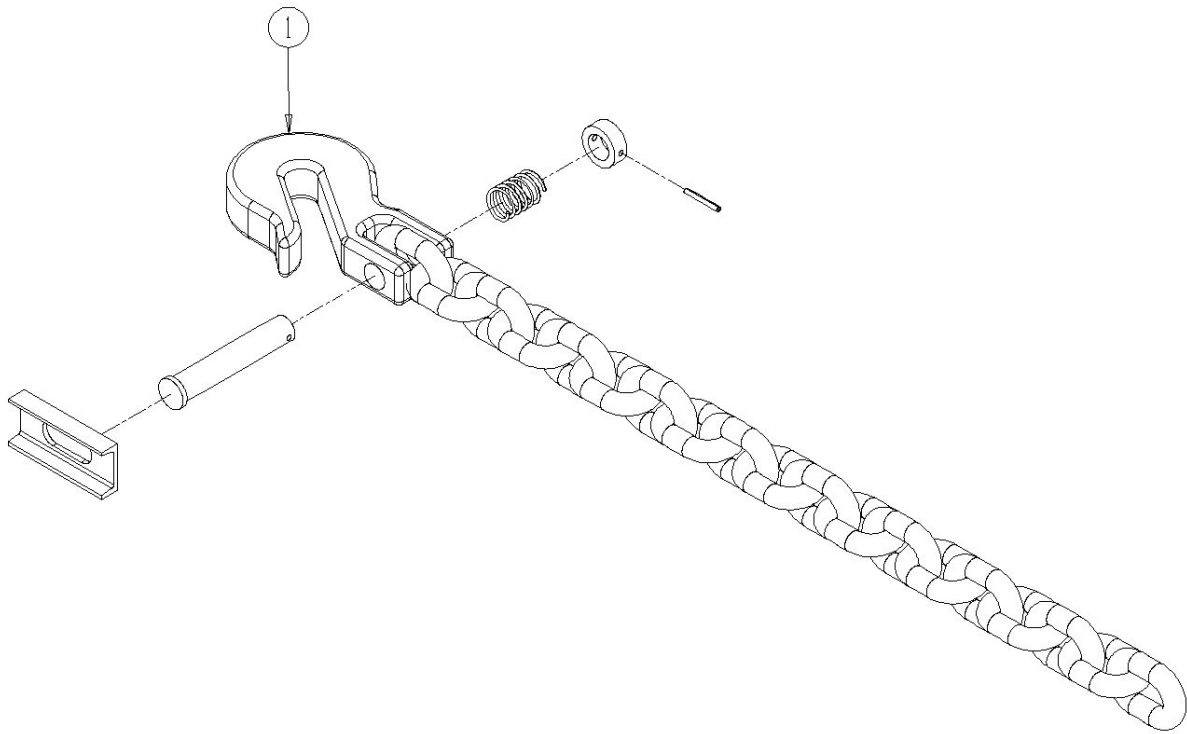

7103-4-3 Jack Stand

<u>Ref</u>	<u>Part No.</u>	<u>Description</u>	<u>Parts – Assembly</u>	<u>Will Fit SN</u>	<u>Remarks</u>
1	WH-16122	Bulldog Sidewind Swivel Jack, 5,000 lb.	0	-71009001 -70209005	Old Style-Topwind, Part No. 18-450-3
1	WH-16216	Jack Weldment, Sidewind Jack, 9,000 lb.	1	71009002- 70209006-	
2	WH-16402	Sleeve Kit, Spreader, 9k	1	WH-16215 -71009001	
801	WH-16402-A	Pin & Chain Assembly for WH-16402	1	71009002-	
802	WH-16402-B	Weld-On Hub, Implement Side, For WH-16402	1	WH-16215 71009002-	
803	WH-16402-C	Weld-On Hub, Jack Side, For WH-16402	1	71009002-	
804	WH-16122-D	Crank Assy for Bulldog Topwind Swivel Jack	0	-71009001	
805	WH-16122-E	Pin & Chain Assy for Bulldog Topwind Swivel Jack	0	-71009001	

7103-4-3
JACK STAND

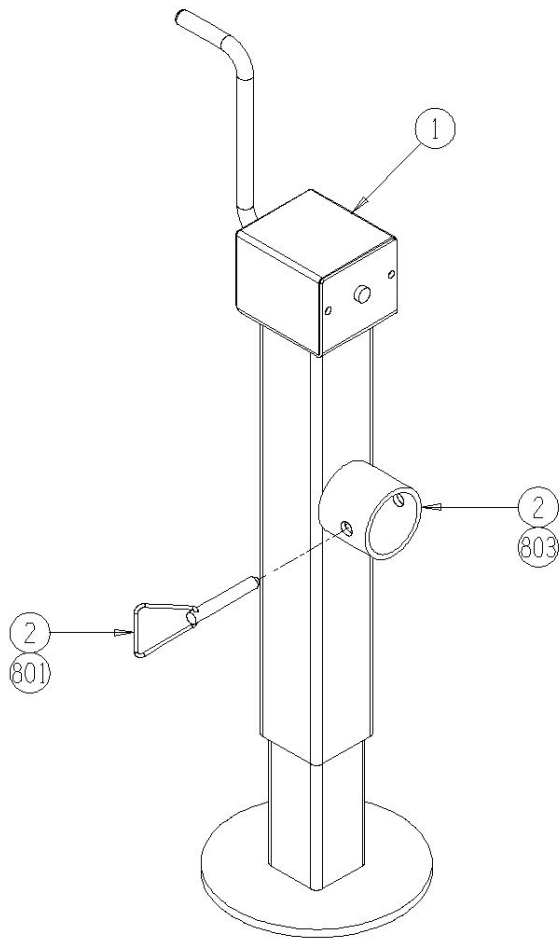

7103-4-4 SMV Emblem & Brackets

<u>Ref</u>	<u>Part No.</u>	<u>Description</u>	<u>Parts – Assembly</u>	<u>Will Fit SN</u>	<u>Remarks</u>
1	SMV-PL	SMV Sign, Metal	1		
2	SMV-S	Socket for Spade Mount	1		
3	SMV-SM	Spade Mount	1		
4	PR39117	Bracket, SMV Sign, Spreader	1		
101	BL-5-075-H	5/16-18 X ¾ HEX CAP G5 ZC	2		
102	BL-4-062-C	1/4" x 5/8" Zinc Carriage Bolt	2		
103	BL-5-LN	5/16-18 HEX LN NE ZC	2		
104	BL-4-LN	1/4-20 HEX LN NE ZC	2		
105	BL-5-FW	5/16 USS FW ZC	2		

7103-4-4
SLOW MOVING VEHICLE EMBLEM & BRACKETS

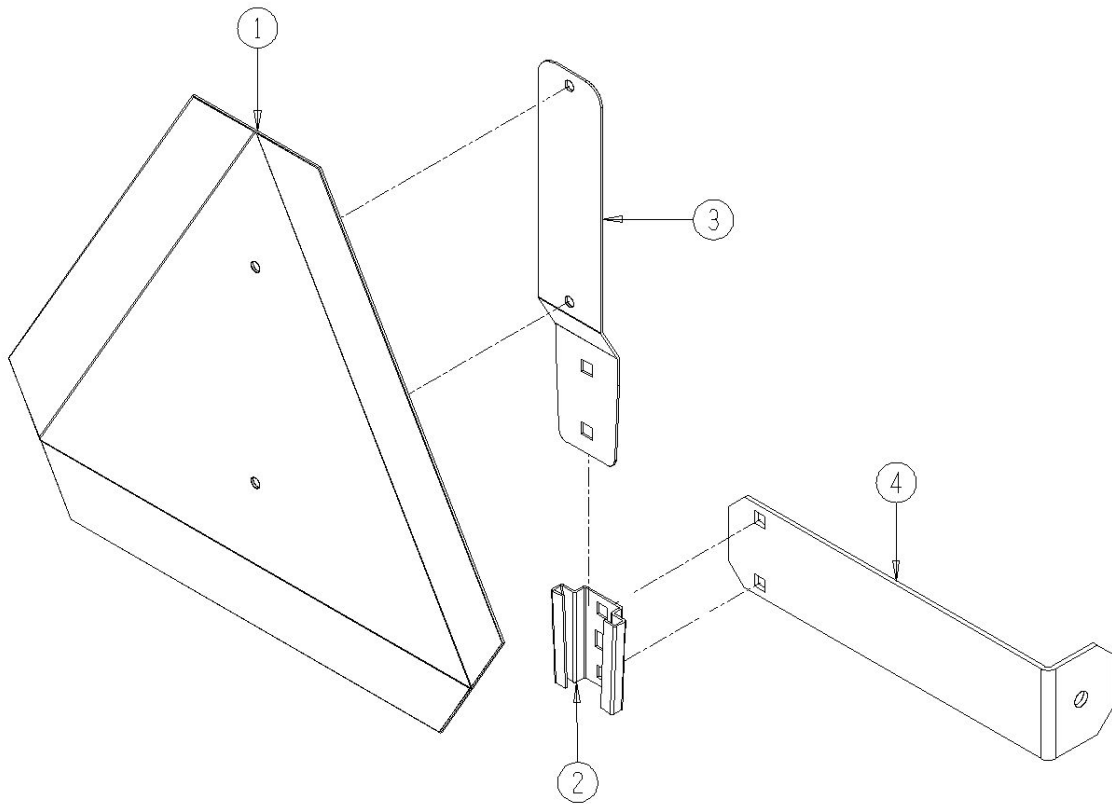

7103-4-5 Decals on Front of Spreader

<u>Ref</u>	<u>Part No.</u>	<u>Description</u>	<u>Parts – Assembly</u>	<u>Will Fit SN</u>	<u>Remarks</u>
0	MAN-0053	Manual, Parts, 1190 Spreader	0		
0	MAN-0054	Manual, Operators, 1190 Spreader	0		
1	DC-0011	Decal, All, 'Made in USA', White Back w/ Red & Blue Letters	1		
2	DC-0020	Decal, Warning, Moving Panel	2		
3	DC-0021	Decal, Caution, 1000 rpm PTO	1		
4	DC-0022	Decal, Tractor Drawbar Adjustments	1		
5	DC-0023	Decal, Caution, Keep All Shields In Place	1		
6	DC-0025	Decal, Danger, Entanglement In Rotating Drive	1		
7	DC-0027	Decal, Warning, Entanglement In Drives	1		
9	DC-0034	Decal, Amber, Reflector, Spreader	1		
10	DC-0052	Decal, 'Hydra Ram Spreaders' Logo, Large	1		
11	DC-0038	Decal, Caution, Raise Endgate Completely	1		
101	RI-3-6-P	Pop Rivets 3/16 x 3/8 Domed, .375 head, ea.	2		

7103-4-5 DECALS ON FRONT OF SPREADER

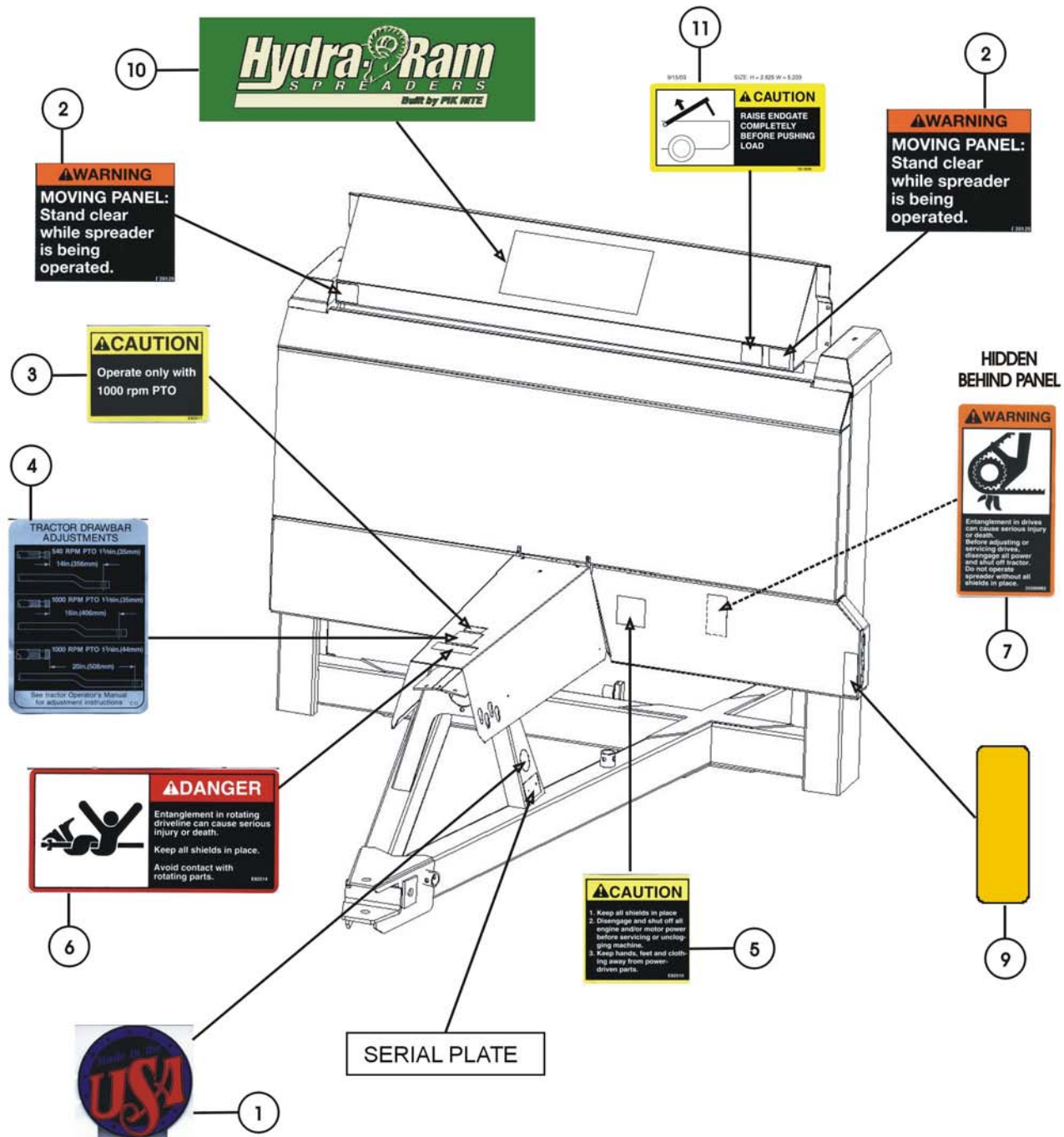

7103-4-6 Decals on Sides of Spreader

<u>Ref</u>	<u>Part No.</u>	<u>Description</u>	<u>Parts – Assembly</u>	<u>Will Fit SN</u>	<u>Remarks</u>
1	DC-0025	Decal, Danger, Entanglement In Rotating Drive	4		
2	DC-0026	Decal, Warning, Crushing Under Endgate	2		
3	DC-0027	Decal, Warning, Entanglement In Drives	1		
4	DC-0030	Decal, Danger, Entanglement In Beater	3		
6	DC-0037	Decal, '1190', Spreader	2		
7	DC-0033	Decal, Red, Reflector, Spreader	2		
8	DC-0038	Decal, Caution, Raise Endgate Completely	1		
9	DC-0052	Decal, 'Hydra Ram Spreaders' Logo, Large	2		

7103-4-6 DECALS ON SIDES OF SPREADER

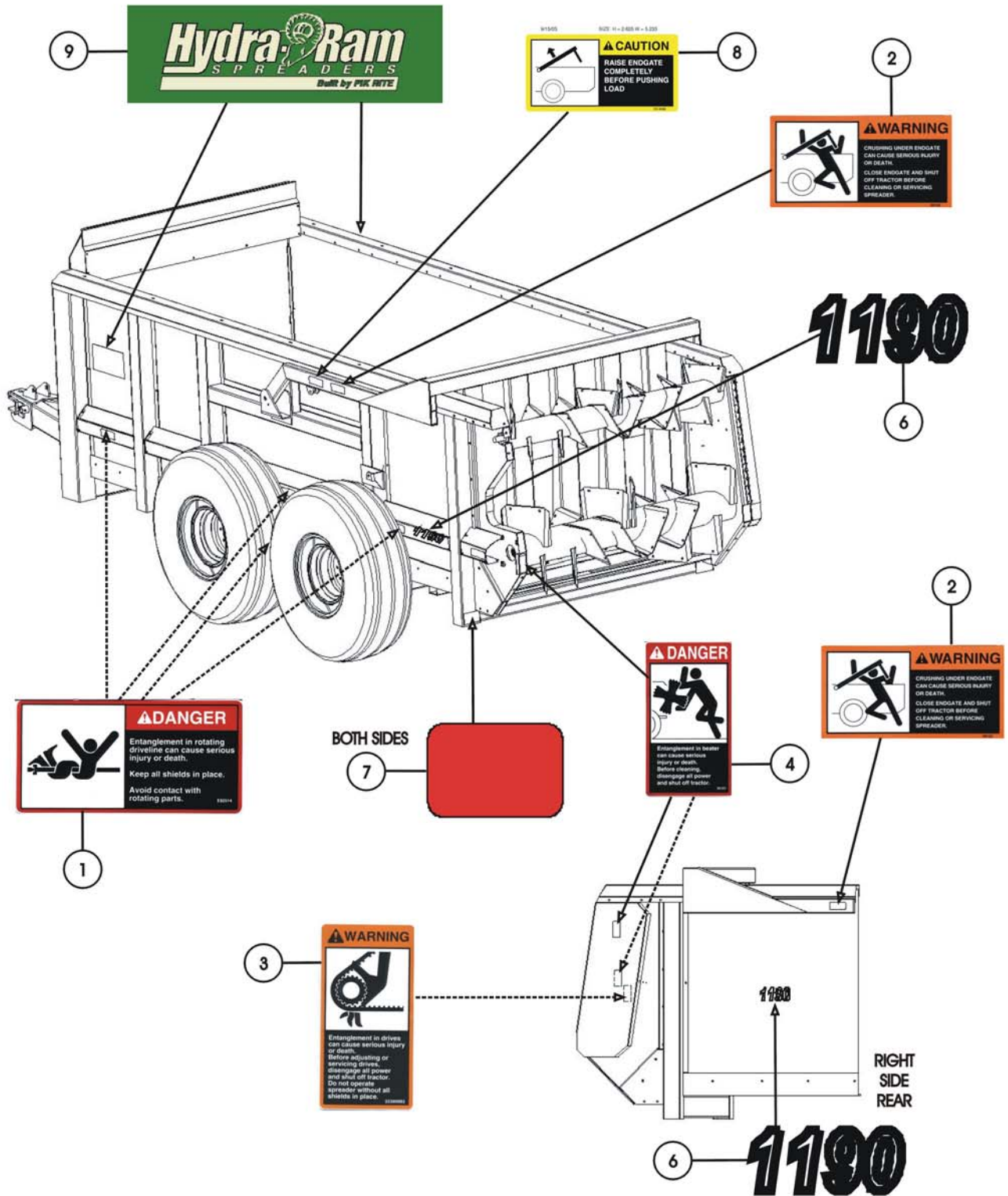

7103-4-8 Manual Holder

<u>Ref</u>	<u>Part No.</u>	<u>Description</u>	<u>Parts – Assembly</u>	<u>Will Fit SN</u>	<u>Remarks</u>
1	MAN-67670	Manual Holder/Canister	1		
101	BL-1224-087-DT	12-24 x 7/8 Drill and Tap Screw	4		

7103-4-8 MANUAL HOLDER

