



OPERATIONS

HYDRA-RAM MANURE SPREADER

MODELS
490, 790, 1190



Pik Rite, Inc
60 Pik Rite Lane
Lewisburg, PA 17837
Ph. 800-326-9763
Fx. 570-523-8175
www.pikrite.com

May 20, 2014

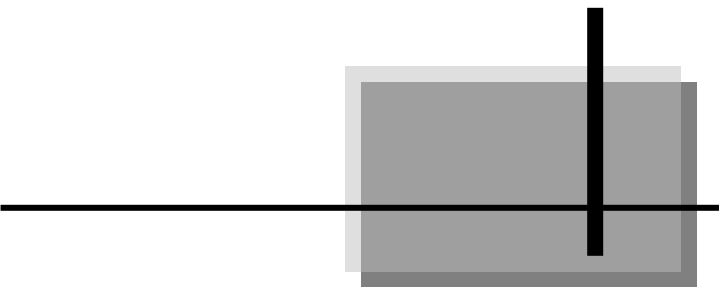

SOME ILLUSTRATIONS MAY NOT REPRESENT THE
SPREADER MODEL YOU HAVE; HOWEVER, THE
PRINCIPLES OF OPERATION AND MAINTENANCE ARE
THE SAME. IF YOU HAVE QUESTIONS SPECIFIC TO
YOUR SPREADER PLEASE CONTACT YOUR DEALER.



HYDRA-RAM MANURE SPREADER

(SPECIFICATIONS AND DESIGN SUBJECT TO CHANGE WITHOUT NOTICE)

WARRANTY

Pik Rite, Inc. provides a limited warranty assuring any new Hydra-Ram Spreader to be free from defects in material and workmanship for a period of two (2) years from the original date of purchase. Pik Rite will repair or replace, at its option and without charge, any defective or malfunctioning part (excluding items of normal wear or misuse) of the spreader for this allotted time.

**PIK RITE MAKES NO WARRANTY OF
MERCHANTABILITY OR FITNESS FOR A
PARTICULAR USE.**

TABLE OF CONTENTS

SAFETY.....	6
PREPARING THE TRACTOR.....	18
PREPARING THE SPREADER	22
CONTROLS.....	25
ATTACHING THE SPREADER.....	27
DETACHING THE SPREADER	31
TRANSPORTING	32
OPERATING THE SPREADER	40
ATTACHMENTS.....	45
LUBRICATION & MAINTENANCE.....	47
SPECIFICATIONS.....	56

SAFETY

RECOGNIZE SAFETY INFORMATION

This is the safety-alert symbol. When you see this symbol on your machine or in this manual, be alert to the potential of personal injury.

Follow recommended precautions and safe operating practices



UNDERSTAND SIGNAL WORDS

A signal word – DANGER, WARNING, or CAUTION—is used with the safety-alert symbol. DANGER identifies the most serious hazards.

DANGER or WARNING safety signs are located near specific hazards. General precautions are listed on CAUTION safety signs. CAUTION also calls attention to safety messages in this manual.

 **DANGER**

 **WARNING**

 **CAUTION**

FOLLOW SAFETY INSTRUCTIONS

Carefully read all safety messages in this manual and on your machine safety signs. Keep safety signs in good condition. Replace missing or damaged safety signs. Be sure new equipment components and repair parts include the current safety signs. Replacement safety signs are available from your Pik Rite dealer.

Learn how to operate the machine and how to use controls properly. Do not let anyone operate without instruction.

Keep your machine in proper working condition. Unauthorized modifications to the machine may impair the function and/or safety and affect machine life.

If you do not understand any part of this manual and need assistance, contact your Pik Rite dealer.



SAFETY

KEEP SHIELDS IN PLACE

Do not operate spreader without safety shields in place.

Rotating parts can crush or dismember causing death or personal injury.

Disconnect PTO driveline and hydraulic lines from tractor before removing shields for adjustment or service.



PROTECT BYSTANDERS

Never operate the spreader near people.

Do not place rocks, timbers or other solid objects in the spreader. Objects can be thrown great distances causing injury to people.



OPERATE SPREADER SAFELY

Rotating parts can entangle or strike people, resulting in death or personal injury.

Never enter a spreader while in operation.

Operate the spreader from the tractor seat only.

Do not exceed load capacity of the spreader. (See Transporting section).

Reduce speed when turning or traveling on rough terrain. Avoid traveling over loose fill, rocks, ditches or holes.

When working on inclines or slopes, travel uphill or downhill. Keep tractor in gear when traveling downhill.



SAFETY

PARK SPREADER SAFELY

Park spreader on a level surface and block wheels.

Close endgate.

Secure jackstand with pin (A).

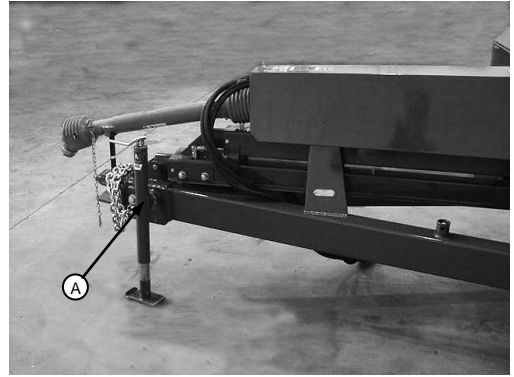

KEEP RIDERS OFF MACHINE

KEEP RIDERS OFF;

Riders are subject to injury such as being struck by foreign objects and being thrown off the machine. Riders also obstruct the operators view resulting in the machine being operated in an unsafe manner.



STAY CLEAR OF RAISED ENDGATE

Contact with a lowering endgate can cause death or personal injury.

Lower endgate and disconnect hydraulic lines before servicing or adjusting.



SAFETY

WEAR PROTECTIVE CLOTHING

Wear close fitting clothing and safety equipment appropriate to the job.

Prolonged exposure to loud noise can cause impairment or loss of hearing.

Wear a suitable hearing protective device such as earmuffs or earplugs to protect against objectionable or uncomfortable loud noises.

Operating equipment safely requires the full attention of the operator. Do not wear radio or music headphones while operating machine.

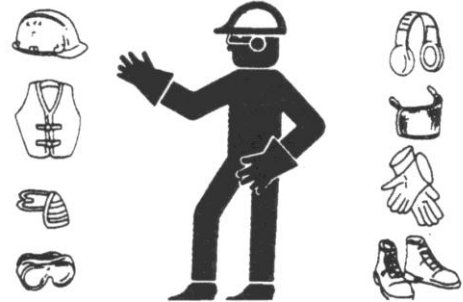

STAY CLEAR OF ROTATING DRIVELINES

Entanglement in rotating driveline can cause serious injury or death.

Keep tractor master shield and driveline shields in place at all times. Make sure rotating shields turn freely.

Wear close fitting clothing. Stop the engine and be sure PTO driveline is stopped before making adjustments, connections, or cleaning out PTO driven equipment.



STAY CLEAR OF ROTATING BEATER

Rotating beater can entangle or strike causing death or personal injury.

Do not clean out or service spreader while beater is rotating.

Disconnect PTO driveline and make sure all parts have stopped rotating before cleaning or servicing.



SAFETY

USE SAFETY LIGHTS AND DEVICES

Slow moving tractors, self-propelled equipment and towed implements or attachments can create a hazard when driven on public roads. They are difficult to see, especially at night. Avoid personal injury or death resulting from collision with a vehicle.

Flashing warning lights and turn signals are recommended whenever driving on public roads. To increase visibility, use the devices provided with your machine. For some equipment, install extra flashing warning lights.

Keep safety items in good condition. Replace missing or damaged items.

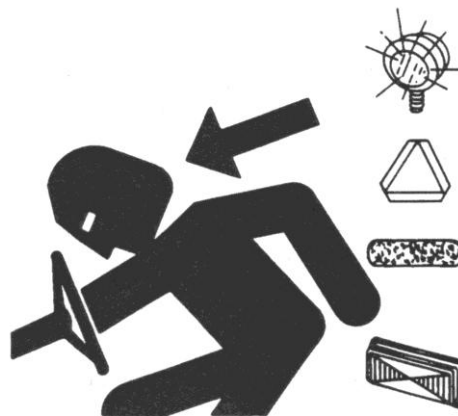

PREPARE FOR EMERGENCIES

Be prepared if a fire starts.

Keep a first aid kit and fire extinguisher handy.

Keep emergency numbers for doctors, ambulance service, hospital, and fire department near your telephone.

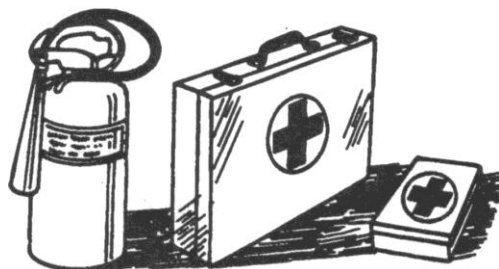

USE A SAFETY CHAIN

A safety chain will help control drawn equipment should it accidentally separate from the drawbar.

Using the appropriate adapter parts, attach the chain to the tractor drawbar support or other specified anchor location. Provide only enough slack in the chain to permit turning.

See your Pik Rite dealer for a chain with a strength rating equal to or greater than the gross weight of the towed machine. Do not use safety chain for towing.



SAFETY

REDUCE SPEED WHEN TOWING LOADS

Braking to stop towed loads from transport speeds can cause the towed load to swerve and upset. Reduce speed if towed load weighs more than the tractor and is not equipped with brakes.

Follow recommended speed-weight ratio guidelines:

- Maximum speed is 20 mph (32 km/h) when towing loads equal to or less than the tractor.
- Reduce speed to 10 mph (16 km/h) when towing loads more than equal and up to double the tractor weight.
- Do not tow loads exceeding double the tractor weight.
- Use additional caution when towing loads under adverse surface conditions, when turning, and on inclines.



SERVICE SPREADER SAFELY

To help prevent personal injury caused by unexpected movement, be sure to service spreader on level surface.

If spreader is connected to tractor, disengage PTO, engage parking brake and/or place transmission in "PARK," shut off engine and remove key.

If spreader is detached from tractor, block wheels and use safety stands to prevent movement.

Replace all shields after lubricating or servicing.



SAFETY

AVOID HIGH-PRESSURE FLUIDS

Escaping fluid under pressure can penetrate the skin causing serious injury.

Avoid the hazard by relieving pressure before disconnecting hydraulic or other lines. Tighten all connections before applying pressure.

Search for leaks with a piece of cardboard. Protect hands and body from high pressure fluids.

If an accident occurs, see a doctor immediately. Any fluid injected into the skin must be surgically removed within a few hours or gangrene may result. Doctors unfamiliar with this type of injury should reference a knowledgeable medical source.



MODEL 490

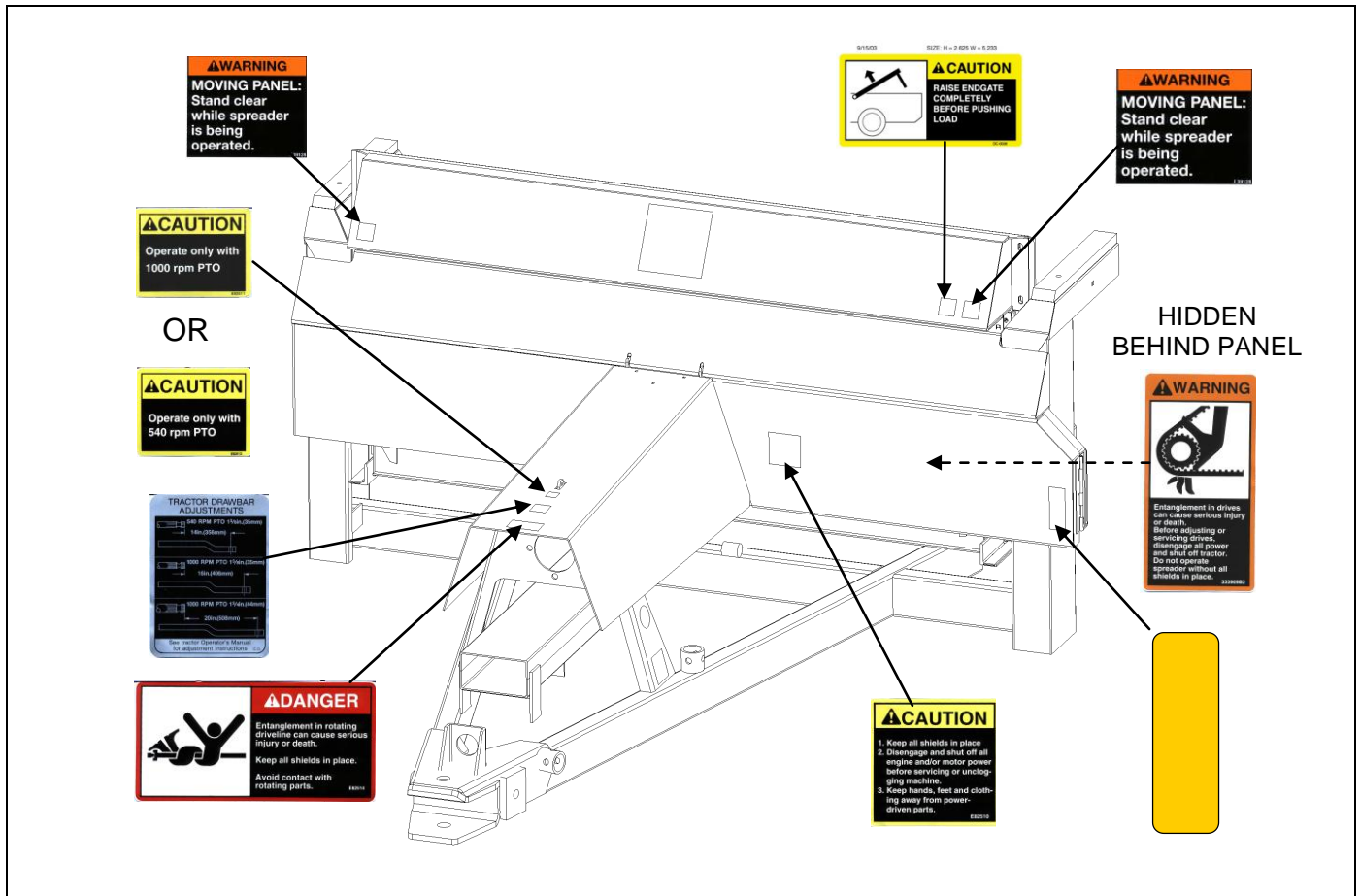

SAFETY MODEL 490

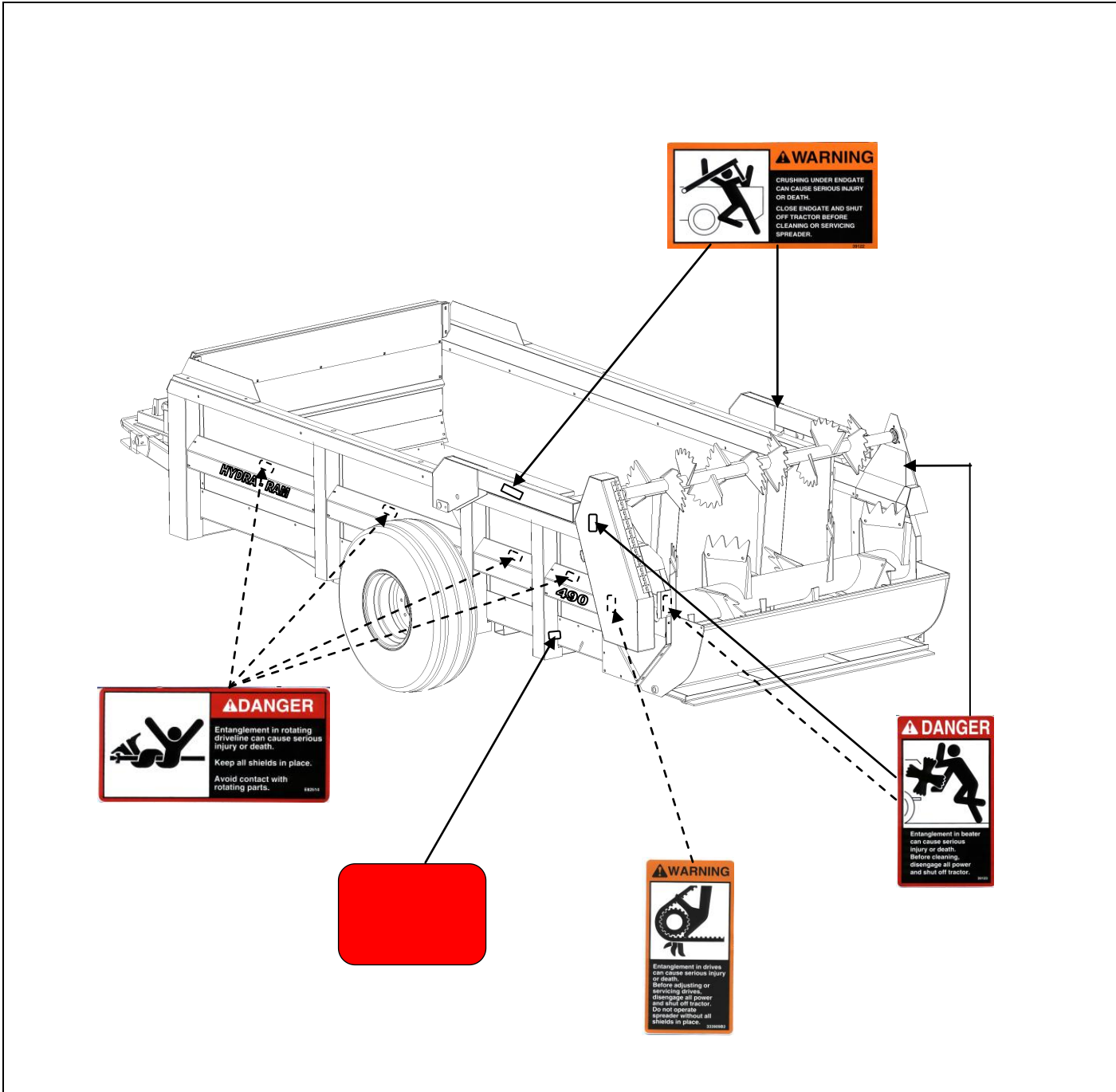

SAFETY MODEL 790

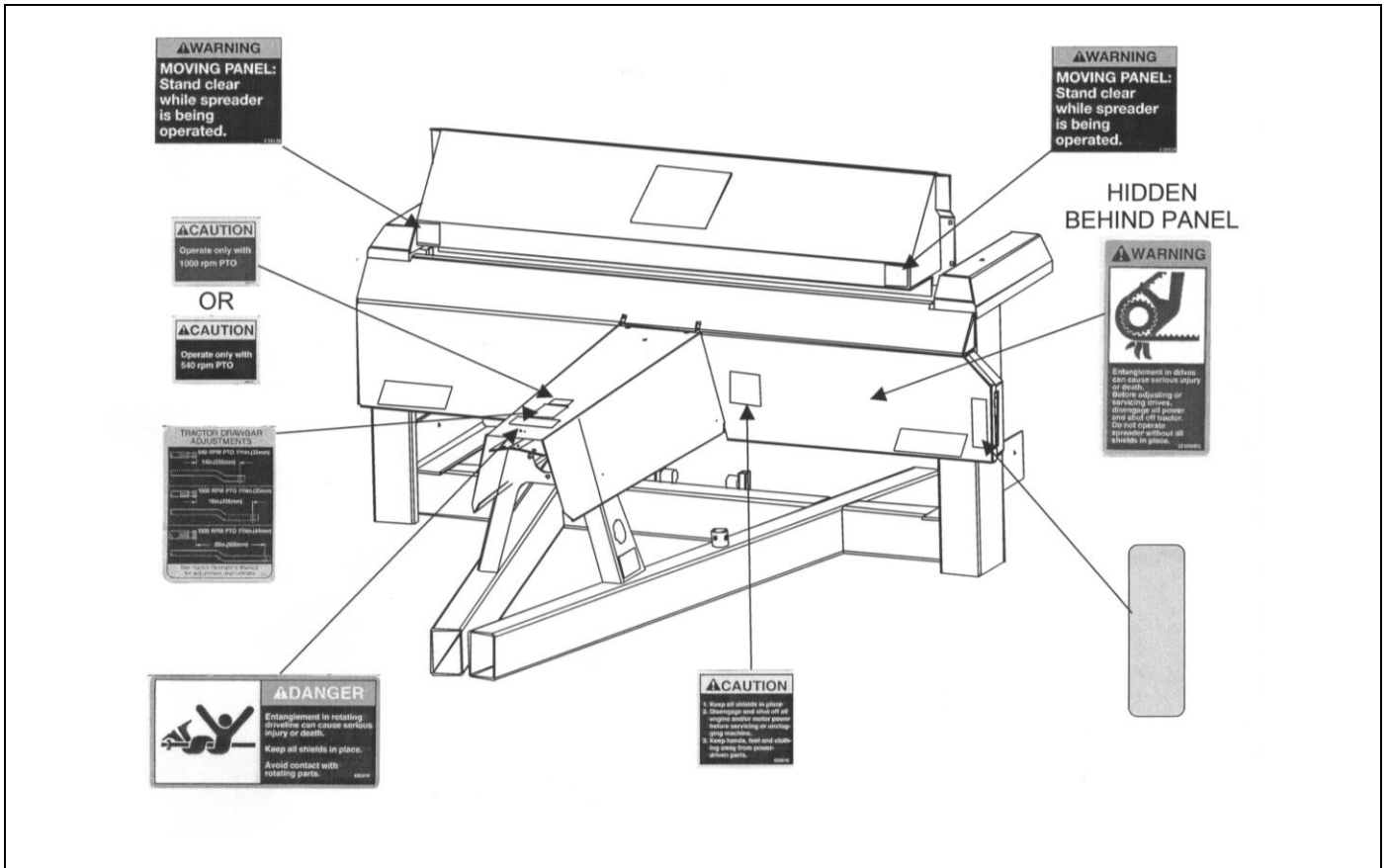

SAFETY MODEL 790

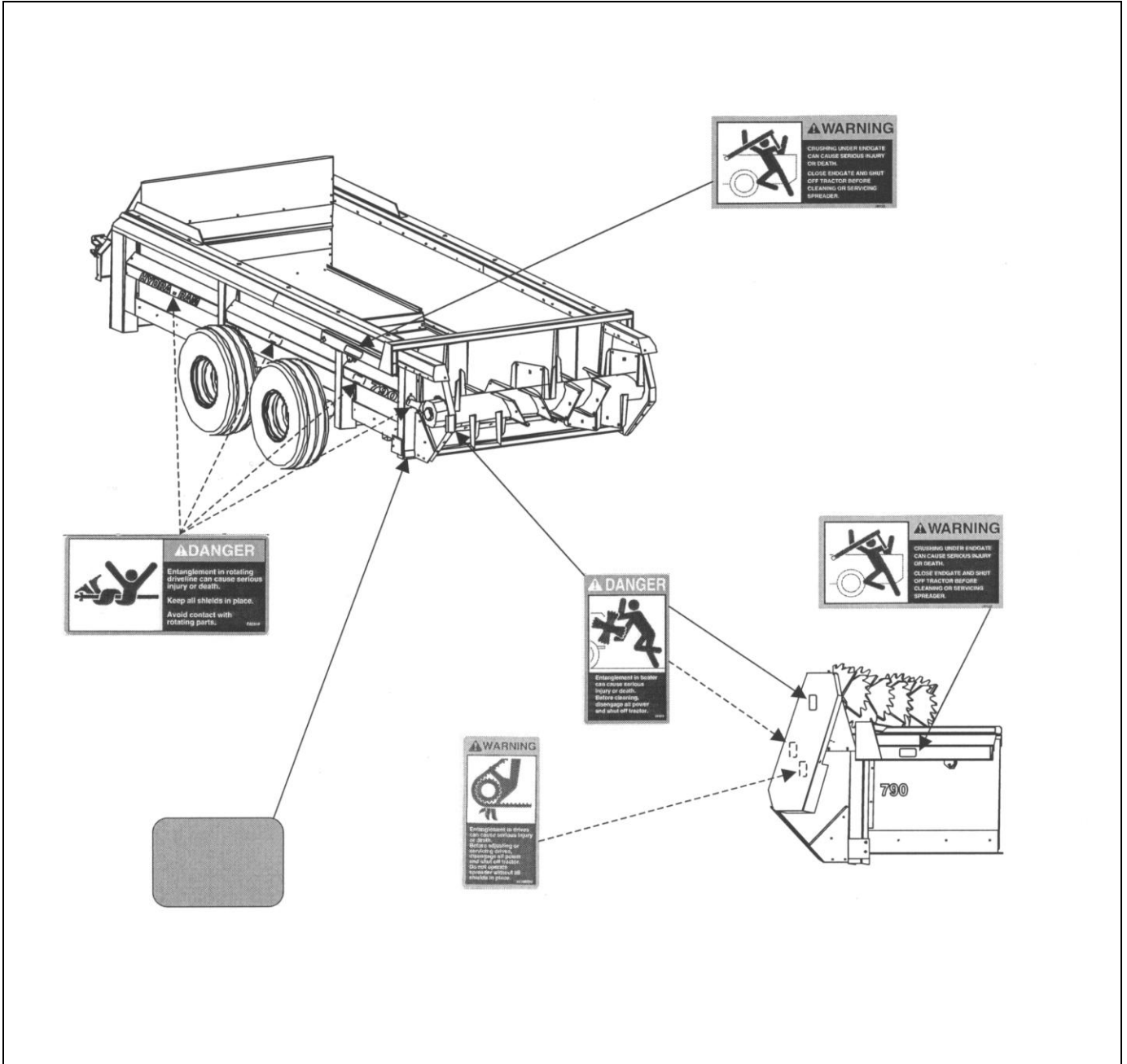

SAFETY

MODEL 1190

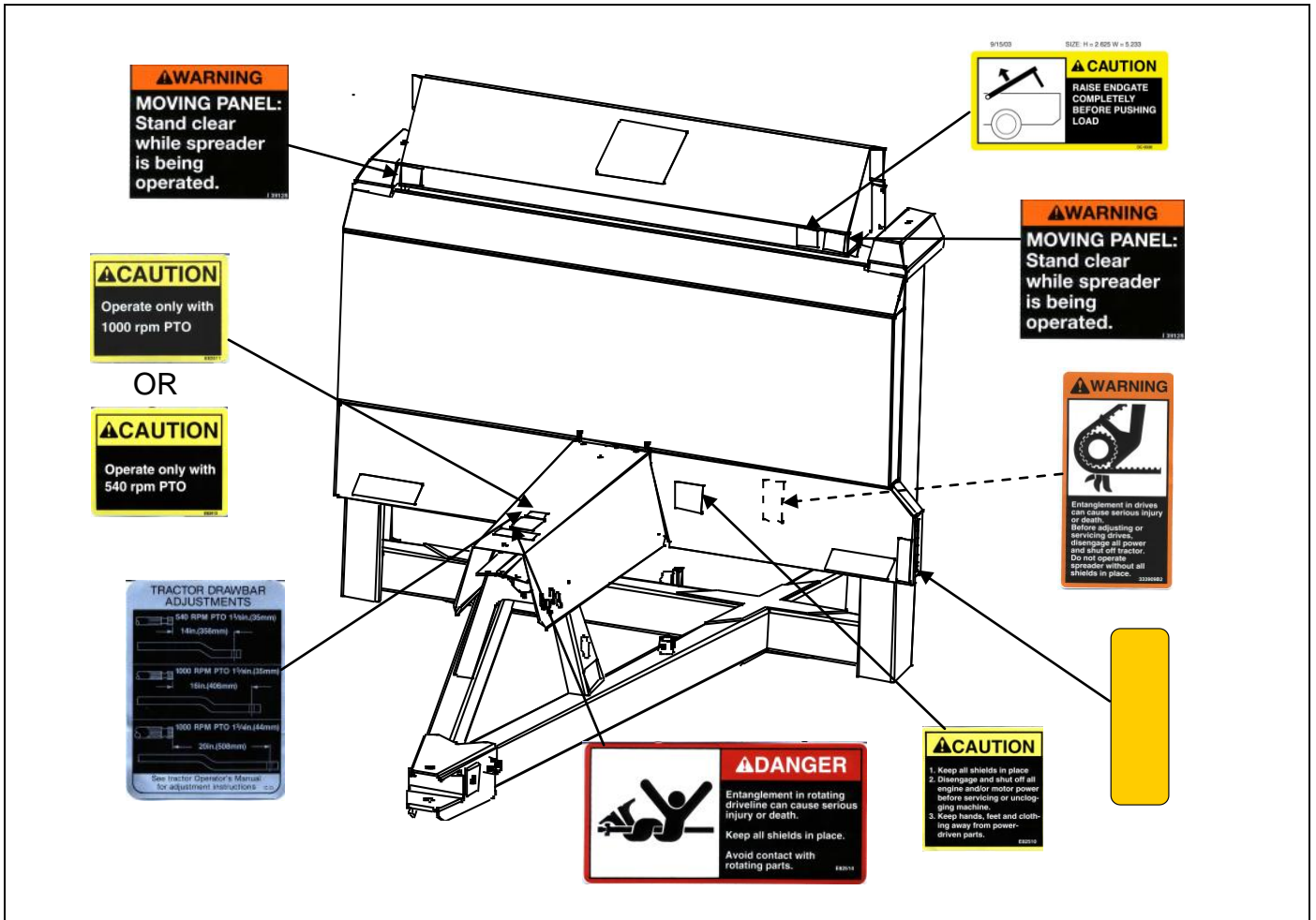

SAFETY

MODEL 1190

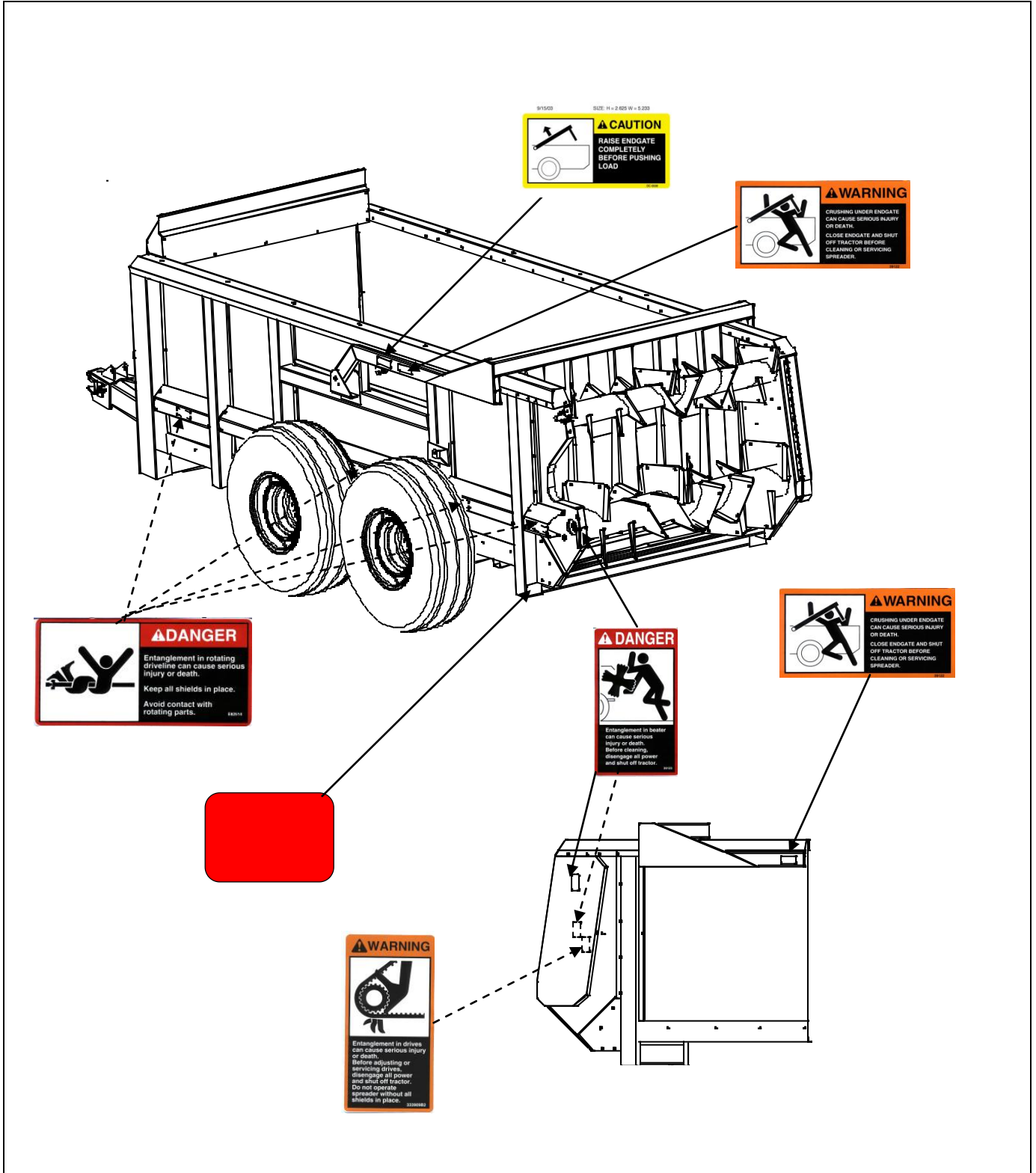

PREPARING THE TRACTOR

APPROVED TRACTORS, MODEL 490

A drawbar support is required on tractors with a drawbar size of less than 1-1/2 x 3 in.

Tractor hydraulic oil reservoir must have capacity for 3.4 U.S. gal. net draw for spreader with endgate or 3.1 U.S. gal. without endgate.

Tractor standby hydraulic pressure must be between 1500 psi and 2250 psi

One selective control valve is required to operate the spreader.

A second selective control valve is required to operate the endgate.

APPROVED TRACTORS, MODEL 790

Row Crop Tractors with 100 HP PTO rating or larger are approved for operation with the 790 Spreader.

Utility Tractors are NOT APPROVED because of drawbar weight limitations and the inability to ballast the tractor enough to meet requirements for towing.

A drawbar support is required on tractors with a drawbar size of less than 1-1/2 x 3 in.

Tractor hydraulic oil reservoir must have capacity for 3.4 U.S. gal. net draw for spreader with endgate or 3.1 U.S. gal. without endgate.

Tractor standby hydraulic pressure must be between 1500 psi and 2250 psi

One selective control valve is required to operate the spreader.

A second selective control valve is required to operate the endgate.

PREPARING THE TRACTOR

APPROVED TRACTORS, MODEL 1190

Row Crop Tractors with 160 HP PTO rating or larger are approved for operation with the 1190 Spreader.

Utility Tractors are NOT APPROVED because of drawbar weight limitations and the inability to ballast the tractor enough to meet requirements for towing.

A drawbar support is required on tractors with a drawbar size of less than 1-1/2 x 3 in.

Tractor hydraulic oil reservoir must have capacity for 3.7 U.S. gal. net draw for spreader with endgate or 3.1 U.S. gal. without endgate.

Tractor standby hydraulic pressure must be between 1500 psi and 2250 psi

One selective control valve is required to operate the spreader.

A second selective control valve is required to operate the endgate.

CHOOSING CORRECT PTO SPEED

MODEL: 490 – 540 rpm std.
790 – 1000 rpm std.
540 rpm opt.
1190 – 1000 rpm std.

IMPORTANT: Drive components can be damaged. Under no circumstances should a machine equipped for 540 rpm PTO be operated by a tractor equipped with 1000 rpm PTO. Nor should a 1000 rpm PTO machine be operated with a tractor equipped with 540 rpm PTO.

Use the 1000 rpm speed for heavy spreading applications that require higher horsepower.

The 540 rpm speed should be limited to light spreading applications that DO NOT require high horsepower.

Transmitting power at 540 rpm requires almost twice as much torque. Continuous operation of 540 rpm at these higher power levels can reduce the life of the beater drive components.

Generally, under similar conditions, the 1000 rpm beater drive components will provide longer life than those for 540 rpm.

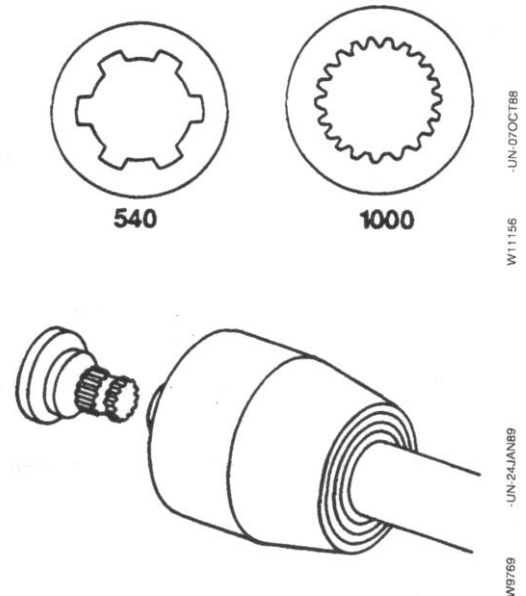

PREPARING THE TRACTOR

BALLASTING THE TRACTOR

CAUTION: Do not tow loads that weigh more than twice the tractor weight. (See Recommended Maximum Towing Speed in Transporting section.)

To ensure proper stability, adjust ballast and wheel spacing according to tractor operator's manual.

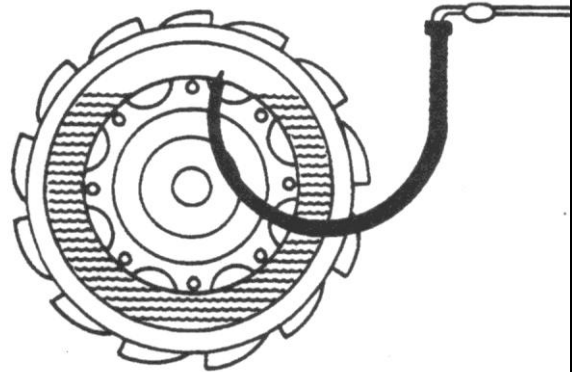

POSITIONING DRAWBAR

IMPORTANT: Tractor PTO and machine driveline can be damaged. Be sure drawbar length is properly set. If equipped with clevis, remove it. Lock drawbar along tractor centerline with offset down.

Remove clevis if equipped.

Adjust drawbar length (A) (see below) to help prevent driveline damage.

PTO Speed	Dimension (A)
540 rpm	356 mm (14 in.)
1000 rpm	406 mm (16 in.)

A tractor drawbar support is required on tractors with a drawbar size of less than 1-1/2 x 3 in..



PREPARING THE TRACTOR

USING SELECTIVE CONTROL LEVERS TO CONTROL FLOOR SPEED

Floor and moving panel speed can be controlled by using tractor selective control lever to extend and retract cylinders.

Adjust selective control valve lever to provide the slowest operating speed. (See your tractor operator's manual).

Maximum hydraulic oil flow through the spreader control valve is 6.8 gpm. Trying to force through more oil than this, may create a pressure drop.

SETTING HYDRAULIC SPEED ENDGATE OPERATION

IMPORTANT: Excessive operating speed may cause machine damage. Adjust selective control valve lever to provide correct operating speed.

Adjust selective control valve lever, it should take two to three seconds to fully extend or retract the cylinder. (See your tractor operator's manual).

CHECKING TRANSMISSION/HYDRAULIC OIL LEVEL

Cycle all hydraulic cylinders fully two or three times.

Fully retract all cylinders.

Check transmission/hydraulic oil level. (See your tractor operator's manual.)

PREPARING THE SPREADER

LUBRICATING THE MACHINE

Be sure the machine has been adequately lubricated.
(See Lubrication and Maintenance page.)

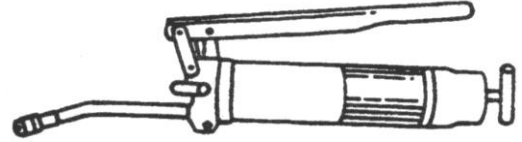

TIGHTENING WHEEL HARDWARE

IMPORTANT: Operating the spreader with loose wheel hardware will damage the hub or wheel. Tighten hardware after initial transport, after one hour of operation, and every fifty hours thereafter.

Tighten to 170 lb-ft in the sequence shown.

Note: Proper installation of the walking beam (rocker) is with the longest leg toward the direction of travel – front.

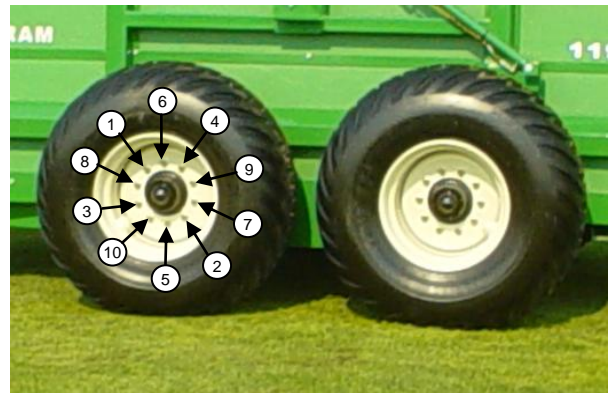
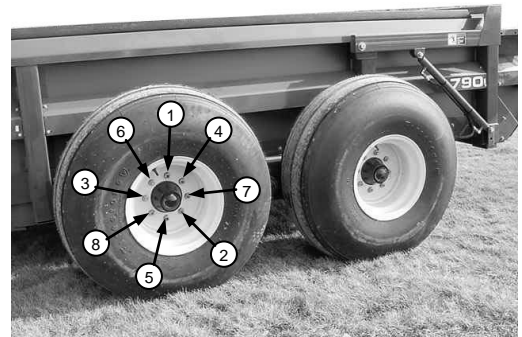

PREPARING THE SPREADER

CHECKING TIRES

1. Check tires daily for damage or noticeably low pressure.
2. Repair any cuts or breaks as soon as possible.
3. Protect tires from exposure to sunlight and petroleum products or chemicals.



SLIPPING THE CLUTCH, WALTERSHIED

Before initial operation and after long periods of inactivity, the clutch must be slipped to prevent the friction plates from sticking. This is done as follows:

1. Tighten all 4 nuts (A) uniformly until the spring load is low enough that the clutch slips freely with the PTO engaged.
2. Turn nuts fully back. Clutch is ready for use.

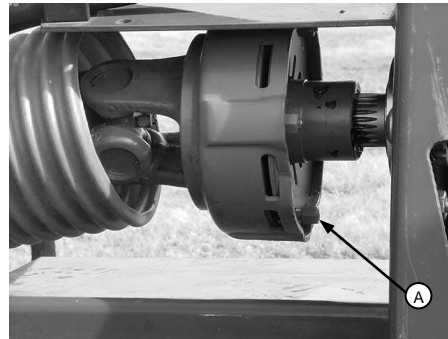

PREPARING THE SPREADER

SLIPPING THE CLUTCH, BONDIOLI MODEL FT

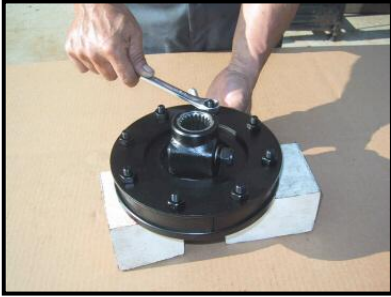

Loosen the bolts evenly and progressively (i.e. do not remove each nut completely in sequence) to uniformly reduce the spring load, 2 or 3 full turns.

To slip the clutch, spin the driveshaft and verify that the clutch plates have been released. The implement drive should not spin when the driveshaft is spun. If it does, loosen the clutch bolts further and repeat the procedure.

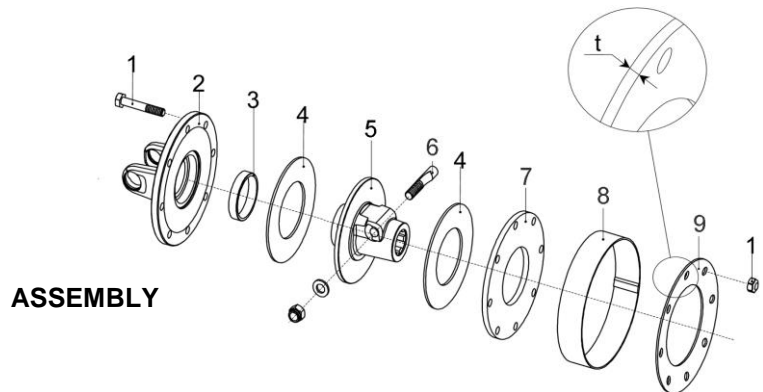

After assuring the clutch plates have slipped, tighten the bolts progressively (i.e. one turn each at a time) in order to compress the spring uniformly.

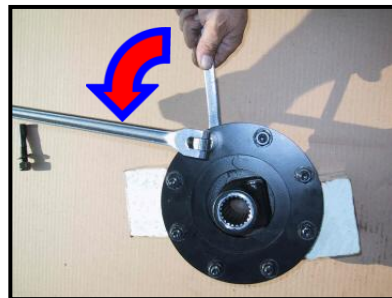

Tighten the bolts until the band (8) is firmly pressed between the flange yoke (2) and spring (9). Back each screw off by 1/4 turn. This will set the compression of the spring to the proper height.

CONTROLS

OPERATING THE BEATER

To start beater, engage PTO lever slowly, at low engine rpm.

To stop beater, disengage PTO. (See your tractor operator's manual.)

For best spreading results, operate the tractor engine at "PTO RATED" speed.

Warning: Do not operate the pusher/sliding floor without running the beaters as this may damage the spreader

OPERATING THE ENDGATE

IMPORTANT: Contact of sliding floor/moving panel with endgate will cause damage. To avoid contact with sliding floor, endgate must be raised a minimum of 6 in. To avoid contact with moving panel, endgate must be raised fully.

Operate the endgate with the second auxiliary control valve lever.



OPERATING SLIDING FLOOR/MOVING PANEL USING METERING CONTROL VALVE

To extend the sliding floor (A) and moving panel (B), lock control lever in operating position.

To retract the sliding floor/moving panel, move control lever in opposite direction.

See your tractor's operating manual for information on how to control flow rates of your hydraulic system.

Maximum hydraulic oil flow through the spreader control valve is 6.8 gpm. Trying to force through more oil than this, may create a pressure drop.

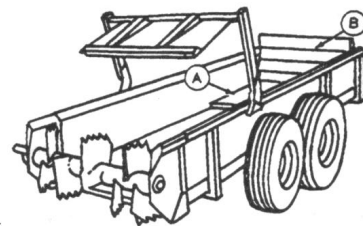

CONTROLS

OPERATING SLURRYPAN

CAUTION: To help prevent personal injury from possible contact with rotating beater, disengage PTO, engage parking brake and/or place transmission in "PARK", shut off tractor, and remove key. Allow beater to stop rotating before opening or closing the slurrypan.

To open, push forward on arm (A) to disengage latch (B).

To close, push rearward on arm (C) to engage latch (B).

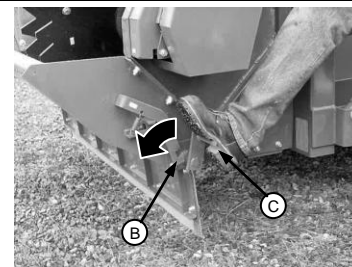
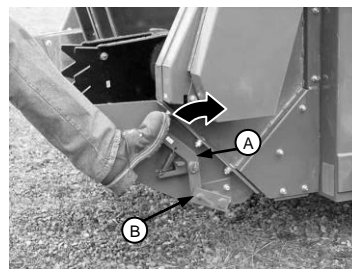

Warning!!

Do not operate spreader with slurry pan open or without latch bars in place as shown.

(If you do not have safety latch bars please contact your local dealer.)

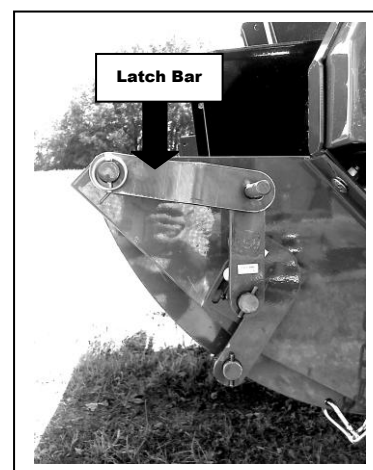

ATTACHING THE SPREADER

ATTACHING SPREADER

CAUTION: Help prevent personal injury caused by unexpected movement of the machine. Engage parking brake and/or place transmission in “PARK”, shut off engine, and remove key before working around hitch.

1. Attach with a 1-1/8 in. pin and secure.

IMPORTANT: Shorten safety chain to allow only enough slack required for turning.

2. Lock safety hook onto chain.

STORING JACKSTAND

1. Remove jackstand from lift position (A).
2. Store jackstand as shown and secure with pin (B).

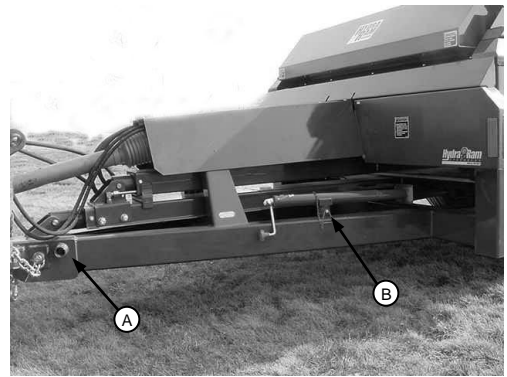

ATTACHING THE SPREADER

ATTACHING DRIVELINE

IMPORTANT: Avoid causing damage to shielding, **DO NOT** use bell on driveline to lift driveline into position.

1. Support driveline, cradling it in your hand.
2. Rotate driveline (C) or tractor PTO (B) to align splines.
3. Pull collar (C) rearward and push forward on bell (A) to engage driveline yoke with tractor PTO (B).
4. Pull back on PTO driveline shielding to be sure driveline is locked. **DO NOT** pull on collar, this will release latch.

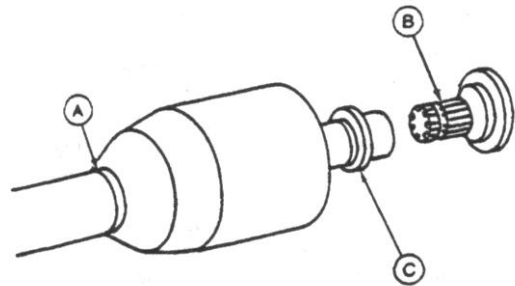

CONNECT HYDRAULIC HOSES

CAUTION: To avoid injury from escaping hydraulic oil under pressure, relieve the pressure in the system by shutting off the tractor and moving remote cylinder operating levers in both directions before attaching hoses to or detaching hoses from the breakaway couplers.



ATTACHING THE SPREADER

CONNECTING HYDRAULIC HOSES TRACTOR WITH CLOSED CENTER HYDRAULIC SYSTEM

Attach control valve to tractor where it can be reached by the operator.

Attach hoses accordingly.

(Diagram shows unloading configuration, flow reverses to retract.)

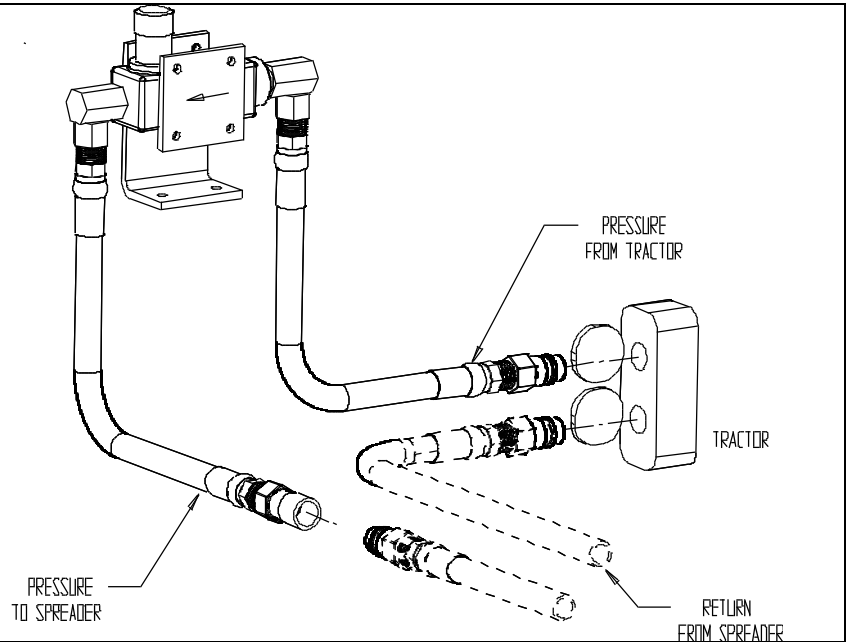

CONNECTING HYDRAULIC HOSES TRACTOR WITH OPEN CENTER HYDRAULIC SYSTEM

Attach control valve to tractor where it can be reached by the operator.

Attach hoses accordingly.

(Diagram shows unloading configuration, flow reverses to retract.)

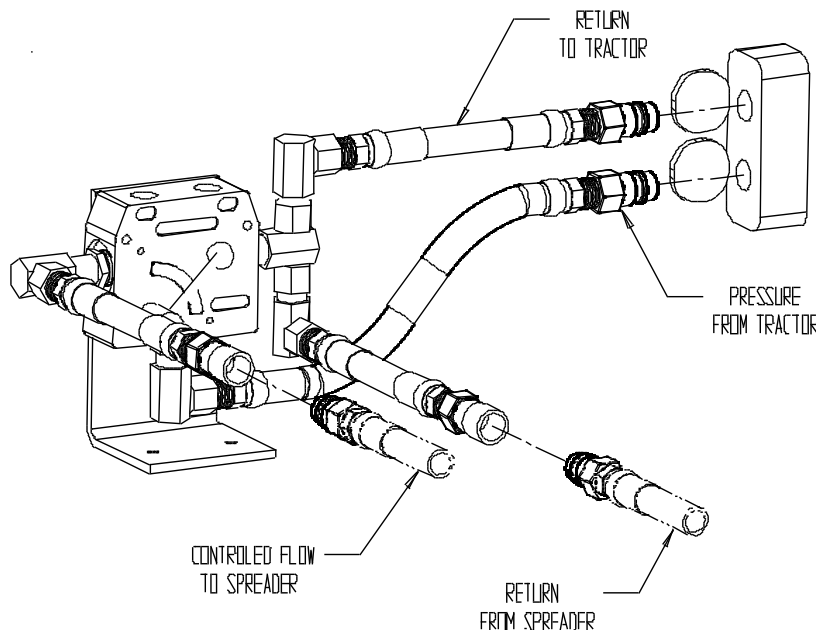

ATTACHING THE SPREADER

CONNECTING ENDGATE HYDRAULIC HOSES

1. Connect pressure hose to pressure port of hydraulic remote coupler.
2. Connect return hose to return port of hydraulic remote coupler.

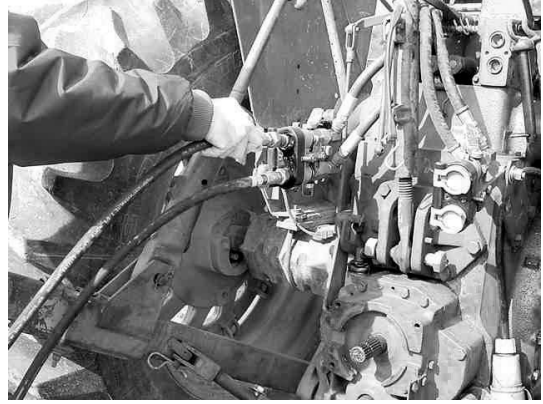

DETACHING THE SPREADER

DETACHING SPREADER

1. Remove jackstand from storage position, place and secure in lift position.
2. Detach safety chain.
3. Remove hitch pin.
4. Disconnect hoses and control valve. Store on spreader.



DETACHING DRIVELINE

1. Support driveline (A) and pull rearward on collar (C) to release driveline from tractor PTO (B).
2. When possible store driveline in driveline cradle provided with machine.
3. Replace tractor PTO shields.

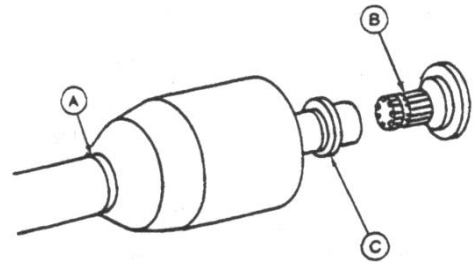

TRANSPORTING

USING A SAFETY CHAIN

CAUTION: A safety chain will help control drawn equipment should it accidentally separate from the drawbar while transporting. Using the appropriate adapter parts, attach the chain to the tractor drawbar support or other specified anchor location. Provide only enough slack in the chain to permit turning. See your Pik Rite dealer for a chain with a strength rating equal to or greater than the gross weight of the towed machine.

1. Attach safety tow chain.

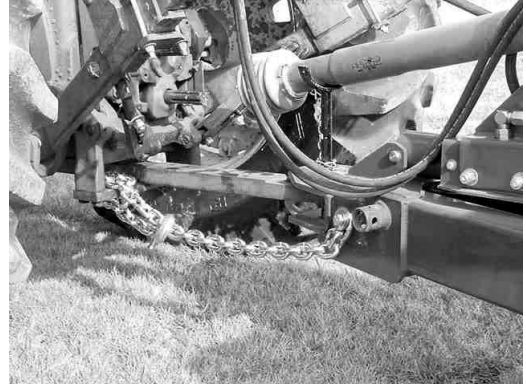

CAUTION: When transporting the machine on a road or highway at night or during the day, use accessory lights and devices for adequate warning to operators of other vehicles. Check local governmental regulations. Keep safety items in good condition. Replace missing or damaged items.

Contact your Hydra-Ram Dealer for available lighting kit.

TRANSPORTING

CAUTION: Braking to stop towed loads from transport speeds can cause the towed load to swerve and upset. Reduce speed if towed load is not equipped with brakes and weighs more than the tractor.

Follow recommended speed-weight ratio guidelines:

- Maximum speed is 20 mph (32 km/h) when towing loads equal to or less than the weight of the tractor.
 - Reduce speed to 10 mph (16 km/h) when towing loads more than or up to double the tractor weight.
 - **DO NOT** tow loads that exceed double the tractor weight.
 - Use additional caution when towing loads under adverse road surface conditions (i.e. slippery or rough), when turning and/or on inclines.
2. For proper tractor size and towing speed see the following “Recommended Maximum Towing Speed” chart.
 3. If necessary, add ballast as described in your tractor operator’s manual.



TRANSPORTING

MAXIMUM SPREADER LOAD CAPACITIES, MODEL 490

The chart on the following page lists various loads and load densities. Recommended towing speeds according to approximate weights and densities of material are provided.

For an exact weight of loads being transported, the load would have to be weighed on scales.

The maximum load carrying capacity of the spreader is 13000 lb.

An example of total towed weight calculation for a 490 Spreader with a load piled 15 in. above the beater consisting of semi-solid type manure would be as follows.

Capacity of spreader - 206 cu. ft.

Weight of material - 55 lb. / cu. ft.

Weight of spreader - 3360 lb.

Calculation of total towed weight - $206 \times 55 + 3360 = 14690$ lb.

TRANSPORTING MODEL 490

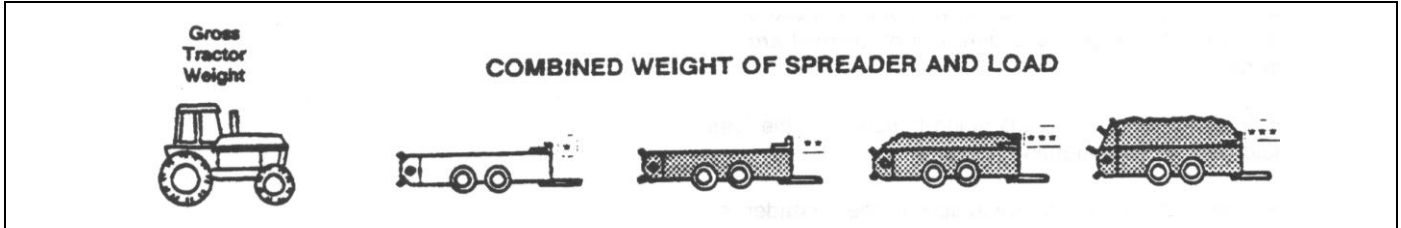

<u>Tractor Weight</u>				
(0-2997 lb)	Do Not Tow	Do Not Tow	Do Not Tow	Do Not Tow
(2998-5950 lb)	(10 mph)	(10 mph)	Do Not Tow	Do Not Tow
(5951-11021 lb)	(20 mph)	(10 mph)	(10 mph)	Do Not Tow
(11022-12123 lb)	(20 mph)	(20 mph)	(10 mph)	(10 mph)
(12124-14769 lb)	(20 mph)	(20 mph)	(10 mph)	(10 mph)
(14770-22044 lb)	(20 mph)	(20 mph)	(20 mph)	(10 mph)
(22045-24910 lb)	(20 mph)	(20 mph)	(20 mph)	(20 mph)
(24911-29540 lb)	(20 mph)	(20 mph)	(20 mph)	(20 mph)
(29541 lb-Up)	(20 mph)	(20 mph)	(20 mph)	(20 mph)

**Base Spreader Empty Load*

***Load struck level consisting of manure with high liquid content. Calculated at 70 lb/cu ft*

****Load piled 381 mm (15 in.) above beater consisting of semi-solid type manure. Calculated at 55 lb/cu ft*

*****Load piled at 15 in. above optional upper beater consisting of semi-solid type manure. Calculated at 55 lb/cu ft*

TRANSPORTING

MAXIMUM SPREADER LOAD CAPACITIES, MODEL 790

The chart on the following page lists various loads and load densities. Recommended towing speeds according to approximate weights and densities of material are provided.

For an exact weight of loads being transported, the load would have to be weighed on scales.

The maximum load carrying capacity of the spreader is 22600 lb.

An example of total towed weight calculation for a 790 Spreader with a load piled 15 in. above the beater consisting of semi-solid type manure would be as follows.

Capacity of spreader - 341 cu.ft.

Weight of material - 55 lb. / cu.ft.

Weight of spreader - 6640 lb.

Calculation of total towed weight - $341 \times 55 + 6640 = 25395$ lb.

TRANSPORTING MODEL 790

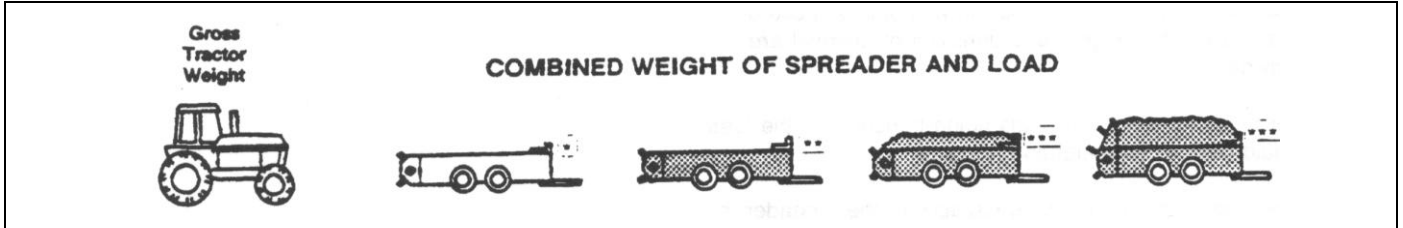

<u>Tractor Weight</u>				
(0-2997 lb)	Do Not Tow	Do Not Tow	Do Not Tow	Do Not Tow
(2998-5950 lb)	(10 mph)	Do Not Tow	Do Not Tow	Do Not Tow
(5951-11021 lb)	(20 mph)	Do Not Tow	Do Not Tow	Do Not Tow
(11022-12123 lb)	(20 mph)	(10 mph)	Do Not Tow	Do Not Tow
(12124-14769 lb)	(20 mph)	(10 mph)	(10 mph)	Do Not Tow
(14770-22044 lb)	(20 mph)	(10 mph)	(10 mph)	(10 mph)
(22045-24910 lb)	(20 mph)	(20 mph)	(10 mph)	(10 mph)
(24911-29540 lb)	(20 mph)	(20 mph)	(20 mph)	(20 mph)
(29541 lb-Up)	(20 mph)	(20 mph)	(20 mph)	(20 mph)

**Base Spreader Empty Load*

***Load struck level consisting of manure with high liquid content. Calculated at 70 lb/cu ft*

****Load piled 381 mm (15 in.) above beater consisting of semi-solid type manure. Calculated at 55 lb/cu ft*

*****Load piled at 15 in. above optional upper beater consisting of semi-solid type manure. Calculated at 55 lb/cu ft*

TRANSPORTING

MAXIMUM SPREADER LOAD CAPACITIES, MODEL 1190

The chart on the following page lists various loads and load densities. Recommended towing speeds according to approximate weights and densities of material are provided.

For an exact weight of loads being transported, the load would have to be weighed on scales.

The maximum load carrying capacity of the spreader is 33400 lb.

An example of total towed weight calculation for a 1190 Spreader with a load piled 15 in. above the beater consisting of semi-solid type manure would be as follows.

Capacity of spreader - 508 cu.ft.

Weight of material - 55 lb. / cu.ft.

Weight of spreader - 9480 lb.

Calculation of total towed weight - $508 \times 55 + 9480 = 37420$ lb.

TRANSPORTING MODEL 1190

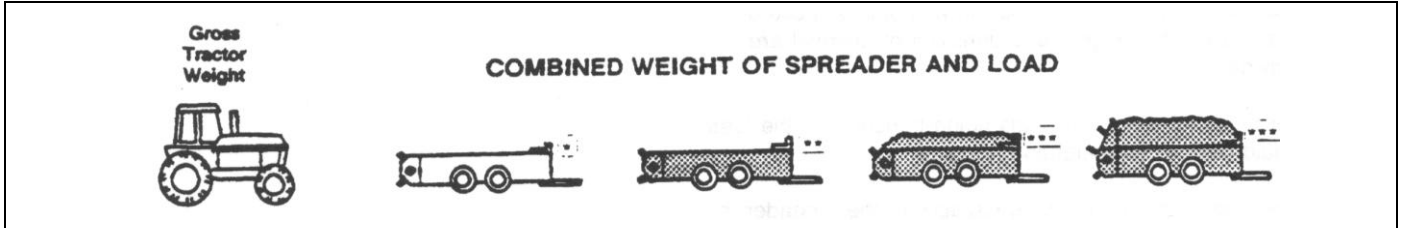

<u>Tractor Weight</u>				
(0-2997 lb)	Do Not Tow	Do Not Tow	Do Not Tow	Do Not Tow
(2998-5950 lb)	(10 mph)	Do Not Tow	Do Not Tow	Do Not Tow
(5951-11021 lb)	(10 mph)	Do Not Tow	Do Not Tow	Do Not Tow
(11022-12123 lb)	(20 mph)	Do Not Tow	Do Not Tow	Do Not Tow
(12124-14769 lb)	(20 mph)	Do Not Tow	Do Not Tow	Do Not Tow
(14770-22044 lb)	(20 mph)	Do Not Tow	Do Not Tow	Do Not Tow
(22045-24910 lb)	(20 mph)	(10 mph)	(10 mph)	(10 mph)
(24911-29540 lb)	(20 mph)	(10 mph)	(10 mph)	(10 mph)
(29541 lb-Up)	(20 mph)	(10 mph)	(10 mph)	(10 mph)

**Base Spreader Empty Load*

***Load struck level consisting of manure with high liquid content. Calculated at 70 lb/cu ft*

****Load piled 381 mm (15 in.) above beater consisting of semi-solid type manure. Calculated at 55 lb/cu ft*

*****Load piled at 15 in. above optional upper beater consisting of semi-solid type manure. Calculated at 55 lb/cu ft*

OPERATING THE SPREADER

PREOPERATING CHECKS

1. Be sure spreader does not contain any foreign objects.
2. Check for correct hydraulic hookup. Raise endgate fully. Cycle sliding floor (A) and moving panel (B). Lower endgate.
3. Retract sliding floor/moving panel to front of spreader.
4. Close endgate and/or endpan.

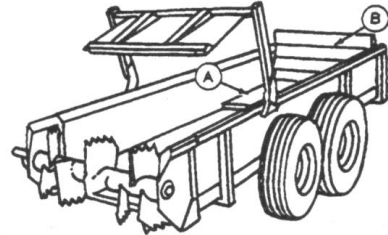

LOADING THE SPREADER

CAUTION: Do not place rocks, timbers, or other solid objects in the spreader. Objects of this nature can damage the spreader and could also be thrown great distances causing possible injury to anyone standing alongside.

Load front of spreader first, distributing load evenly.

When operating without an endgate, avoid loading manure against the beater.



PREPARE TO UNLOAD THE SPREADER

CAUTION: Help prevent personal injury. Be sure no one is near spreader and tractor before operating.

1. Start beater by engaging PTO slowly at low engine rpm. Increase to "PTO RATED" speed.

NOTE: For best spreading results, operate tractor at "PTO RATED" speed.

Warning: Do not operate the pusher/sliding floor without running the beaters as this may damage the spreader

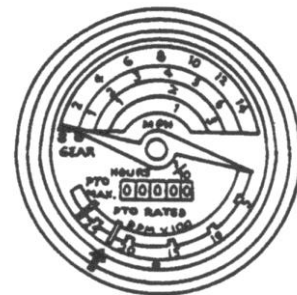

OPERATING THE SPREADER

2. Raise endgate.

IMPORTANT: Contact of the sliding floor or moving panel with endgate will cause damage. To avoid contact with sliding floor, endgate must be raised a minimum of 6 in. To avoid contact with moving panel, endgate must be raised fully.



UNLOADING SPREADER USING METERING VALVE

1. Set flow control device to obtain desired rate of unload speed.

Note: Rate of spread is affected by both ground speed and unload speed. Experience will help you determine both gear selection and control knob setting.

3. When spreader is empty, disengage PTO, retract sliding floor/moving panel, and lower endgate.

OPERATING THE SPREADER

PRODUCING GOOD SPREADING RESULTS

1. Operate tractor engine at "PTO RATED" speed.
2. Do not overload beater. A clumpy spread pattern will result from too fast an unload rate.
3. Use an upper beater when spreading heaped loads. This will help prevent large clumps of material from coming over the top of main beater.
4. When spreading manure with high liquid content, use a slurrypan attachment to keep manure in contact with the beater. This will prevent liquid material from running out under the beater.
5. When operating without an endgate, avoid loading material against the beater. Otherwise, large clumps of material will be thrown out during the first few turns of the beater.

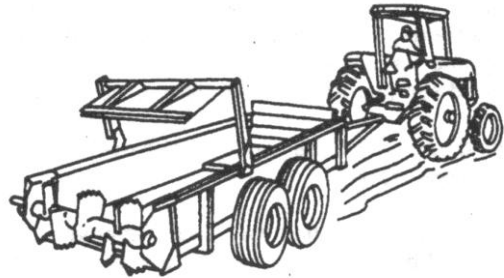

CLEANING SPREADER IN COLD WEATHER

When operating the spreader during extended periods of subfreezing temperatures, frozen material may build up on steel surfaces or wooden guides. This can prevent the sliding floor (A) and/or moving panel (B) from moving.

After completing spreading for the day, use the following cleaning procedure.

NOTE: Cleaning is only necessary during extended periods of subfreezing temperatures.

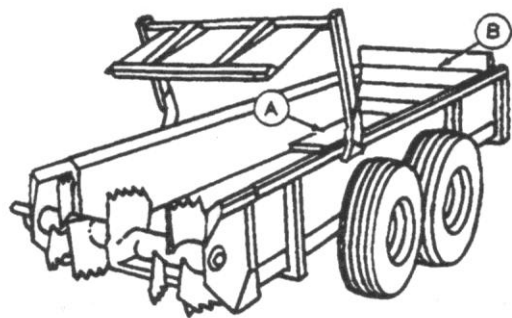

OPERATING THE SPREADER

CAUTION: Help prevent personal injury caused by unexpected movement of the machine. Disengage PTO, engage parking brake and/or place transmission in "PARK", shut off engine, and remove key before cleaning spreader.

1. Extend and retract the sliding floor/moving panel to remove loose material.
2. Extend sliding floor half way back. Remove accumulated material on frame (A), the tops and sides of wood and steel guides (B), and front edge of floor (C), on each side.

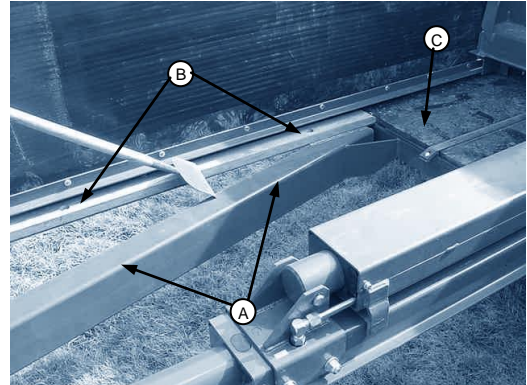

3. Remove accumulated material from rear of moving panel, top of tube (A), and V-section (B).

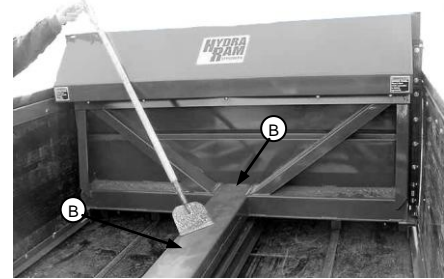

4. Remove material on the rear steel edge of the main floor and bottom of steel side panels (A).
5. Remove material buildup from endgate panel. Keep endgate arms clean to prevent freezing to side rails.

NOTE: Any buildup which prevents the sliding floor from traveling fully rearward, will prevent the moving panel from being activated.



OPERATING THE SPREADER

6. Retract sliding floor and remove material on the underside of the moving panel. (This cleaning is only necessary in prolonged periods of cold weather).

7. When tire valve stems are mounted towards the inside, clean top of walking beams to prevent valve stem damage.

8. Leave moving panel 12 in. from front of spreader to allow cylinder movement in both directions



WARMING HYDRAULIC OIL TEMPERATURES BELOW 0°F (-18°C)

It is necessary to warm the hydraulic oil for proper spreader operation.

Follow the procedures in your tractor operator's manual for warming hydraulic oil.

The following procedures apply only to tractors with a closed center hydraulic system.



BYPASSING SPREADER CONTROL VALVE

There will be a large hydraulic oil pressure drop across the auxiliary flow control valve when the oil is cold. Oil pressure available to hydraulic cylinders may be too low.

Try cycling the cylinders several times slowly so the cold oil in the cylinders is mixed with the warm oil in the tractor. In the event of extreme cold; you may need to bypass the control valve to do this. Be sure you begin by moving the cylinders very slowly.

Extend and retract sliding floor/moving panel to exchange cold oil from spreader cylinders with warmed tractor hydraulic oil.

Reconnect hoses to flow control valve.

ATTACHMENTS

WHEELS AND TIRES

Drop center wheels with recapped truck tires or implement tires are available.

Tire Size	Wheel Size	Tire Pressure
16.5 x 16.1 Implement	14.00 x 16.1	48 PSI
11 R 22.5	22.5 x 8.25	75 PSI
385/65 R 22.5	22.5 x 11.75	115 PSI
550/60 – 22.5 Implement	22.5 x 16	40 PSI
425/65 R 22.5 Truck Tires	22.5 x 13	115 PSI



Implement Tires

UPPER BEATER

An upper beater improves the distribution pattern when spreading heaped loads.



ATTACHMENTS

ENDGATE

The endgate closes off the back end of the spreader to contain manure with high liquid content.

The endgate also prevents solid material from being piled tight against the beater.



SLURRY PAN

The slurry pan (A) keeps manure with high liquid content in contact with the beater for more effective spreading.

A foot-operated latch opens and closes the clean out door at the bottom. (See Operating the Slurry Pan in the Controls section.)

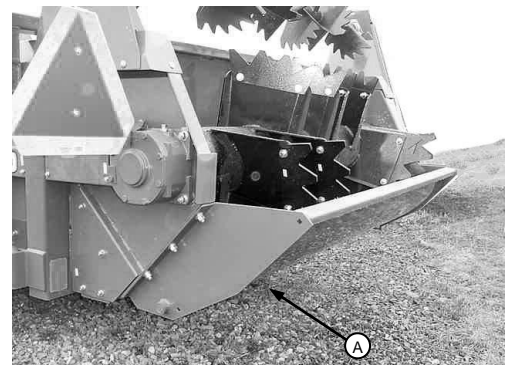

ATTACHING THE SLURRY PAN

Assemble components as shown in parts book. Drill hole through hinge rod located by latch arm and lock in place with roll pin.

LUBRICATION & MAINTENANCE

LUBRICATING AND MAINTAINING SPREADER SAFELY

CAUTION: Help prevent personal injury caused by unexpected movement of the machine. If spreader is connected to tractor, disengage PTO, engage parking brake and/or place transmission in "PARK", shut off engine, and remove key. If spreader is detached, block wheels and use safety stands.

Replace all shields after lubricating or servicing.

OBSERVING INTERVALS

IMPORTANT: The intervals recommended are based on normal conditions. Severe or unusual conditions may require more frequent attention.

Perform each lubrication and maintenance item illustrated in this section.

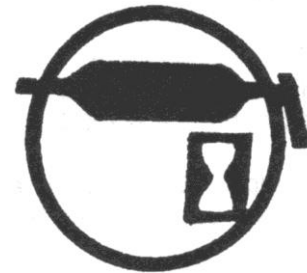

SELECTING GREASE

Depending upon the expected air temperature range during the service interval, use grease as shown on the adjusting temperature chart.

-SAE-Multipurpose High Temperature Grease with Extreme Pressure [EP] Performance with 3 to 5% molybdenum disulfide.

NOTE: Moly-type grease is recommended, however, if not available, a multipurpose grease is acceptable.

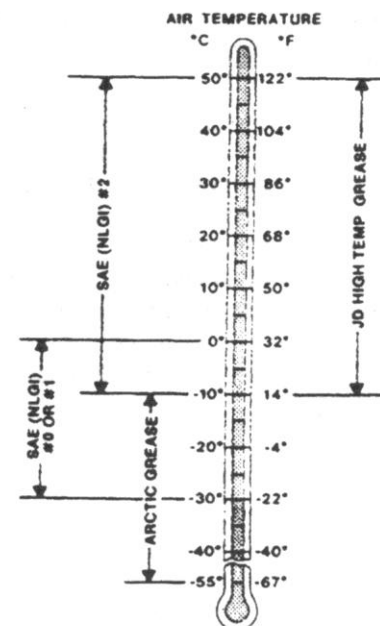

LUBRICATION & MAINTENANCE

SELECTING GEAR CASE OIL

Depending upon the expected air temperature range during the drain interval, use oil viscosity shown on the adjoining temperature chart.

- API Service Classification GL-5
- Military Specification MIL-L-2105B
- Military Specification MIL-L-2105C

At temperatures below -35° [-31°], use arctic oils such as those meeting Military Specifications MIL-G-10324A.

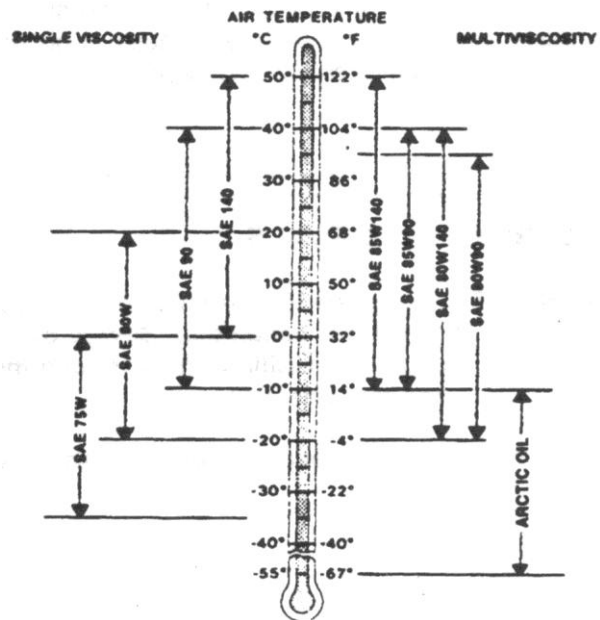

X9322 -19-30SEP88

SERVICE INTERVALS

EVERY 8 HOURS

- Lubricate driveline
- Lubricate drive chains
- Check gear case oil level
- Check tires

EVERY 50 HOURS

- Check clutch friction disk wear
- Tighten wheel hardware
- Lubricate walking beam pivots

EVERY 250 HOURS

- Repack wheel bearings
- Lubricate endgate pivots

SERVICE AS REQUIRED

- Adjust drive chain tension
- Slip the clutch
- Adjust sliding floor/moving panel seals

LUBRICATION & MAINTENANCE

WALTERSHIED

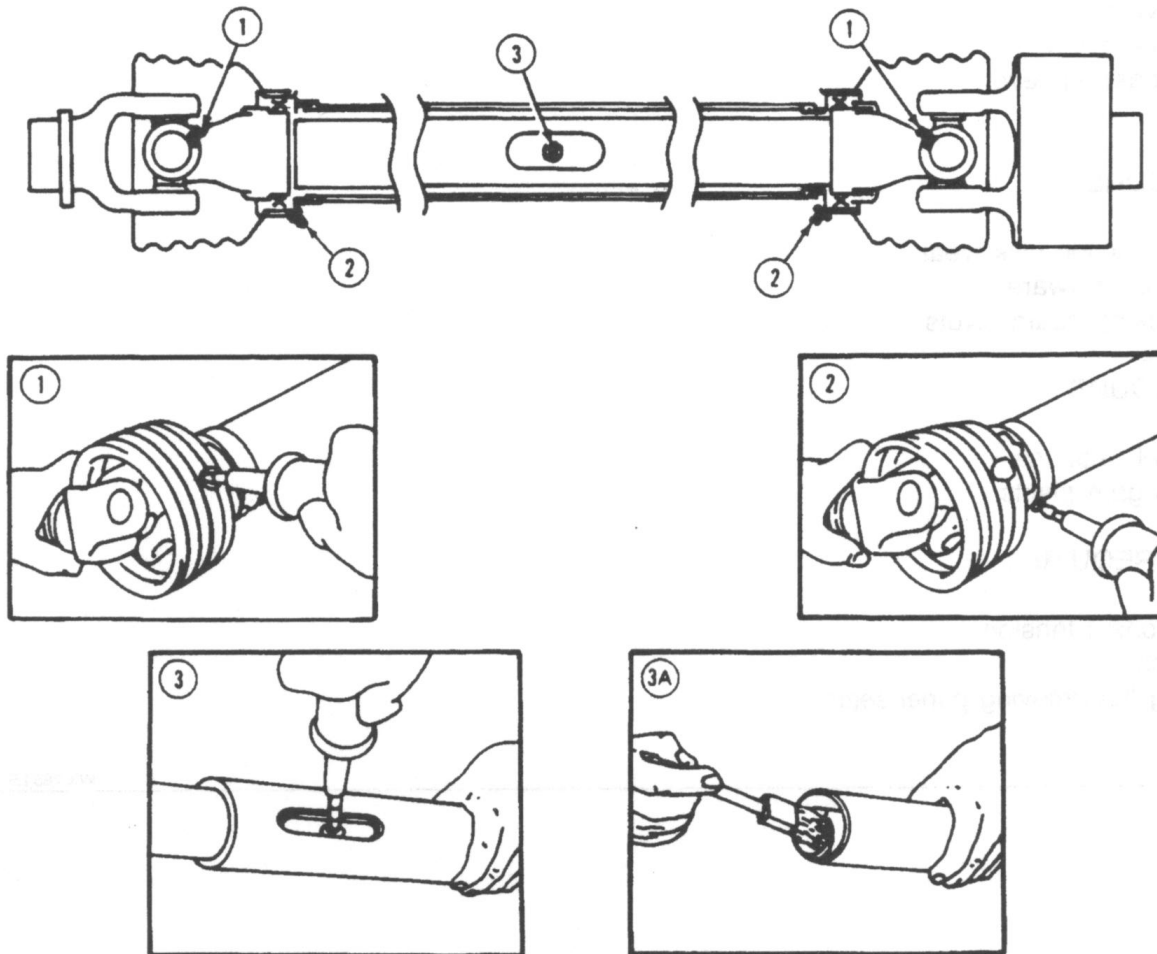

Lubricate fittings 1 through 3 every eight hours of operation.

NOTE: Lubrication step 3A is only necessary when driveline does not have grease fitting outlined in step 3. Separate front and rear halves of driveline and brush with grease.

LUBRICATION & MAINTENANCE

BONDIOLI

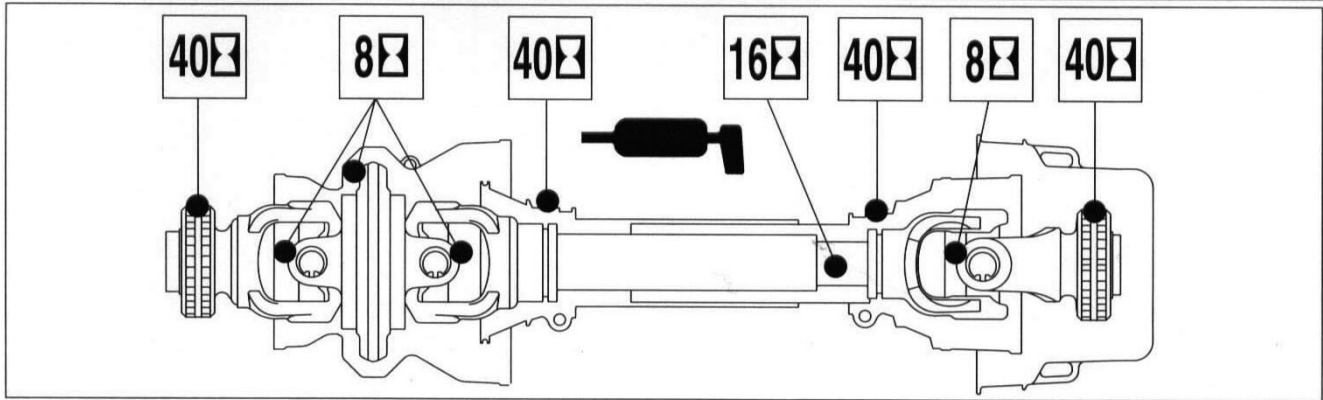

8h

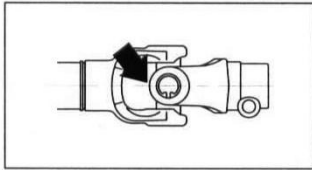

CROSS JOURNAL

16h

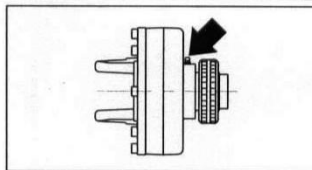

FN - FRICTION TORQUE LIMITER
WITH OVERRUNNING CLUTCH

8h

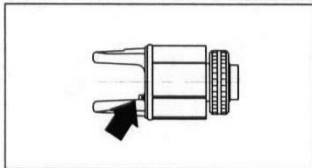

SA - RATCHET
TORQUE LIMITER

16h

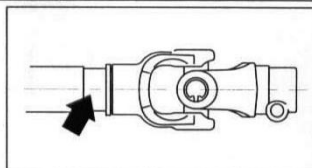

INNER TUBE

8h

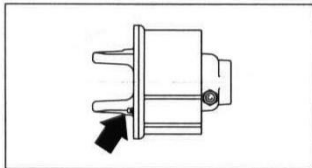

SC - AUTOMATIC
TORQUE LIMITER

40h

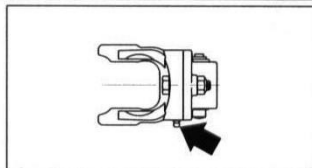

SB - SHEAR BOLT TORQUE LIMITER

8h

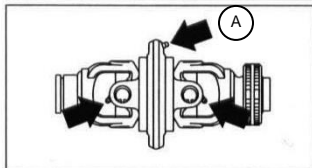

A- 23 Pumps
Required

OC - CONSTANT VELOCITY JOINT

40h

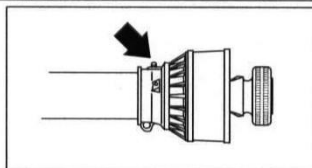

SHIELD RETAINING BEARING

16h

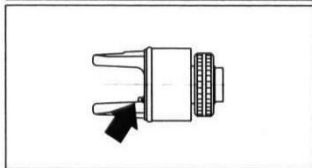

RA - OVERRUNNING

40h

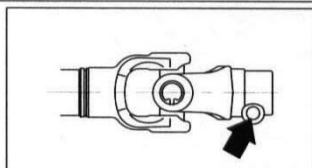

PUSH-PIN

LUBRICATION & MAINTENANCE

CHECK GEAR CASE OIL LEVEL

With spreader on level ground, remove dipstick and check oil level. Add recommended oil as needed. (See Selecting Gear Case Oil.) Fill to full mark through dipstick hole.



LUBRICANT FOR DRIVE CHAINS

Lubricate with a good chain lube or the same oil being used in the engine.

Lubricate chains immediately after operation when the chain is warm.



CHECKING TIRES

1. Check tires daily for damage or noticeably low pressure.
2. Repair any cuts or breaks as soon as possible.
3. Protect tires from exposure to sunlight and petroleum products or chemicals.



LUBRICATION & MAINTENANCE

CHECKING CLUTCH FRICTION DISK WEAR, WALTERSHIED

Edge of thrust plate (A) should be visible in forward window (B). As the internal friction disks wear, the thrust plate moves forward in the housing. Replace friction disks when thrust plate is no longer visible.

To replace friction disks, see your Pik Rite dealer.

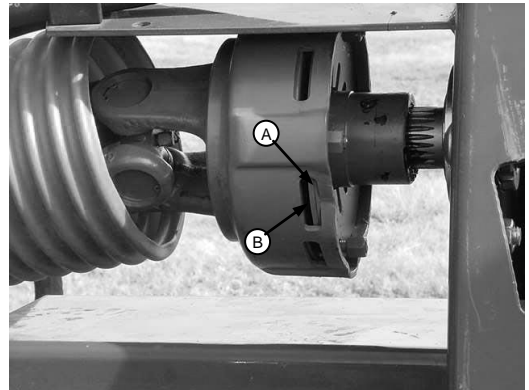

CHECKING CLUTCH FRICTION DISK WEAR, BONDIOLI MODEL FT

If unusual slippage occurs, inspection of the internal components may be necessary. Contact your Hydra-Ram dealer for further instructions.

Reference: FT Clutch Repair document.



TIGHTENING WHEEL HARDWARE

IMPORTANT: Operating the spreader with loose wheel hardware will damage the hub or wheel. Tighten hardware after initial transport, after one hour of operation, and every fifty hours thereafter.

Tighten to 170 lb.-ft. in the sequence shown.

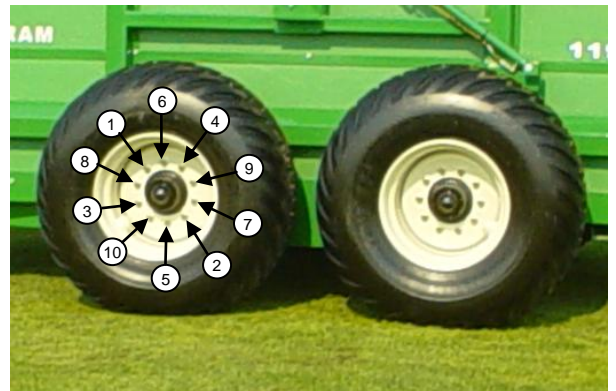
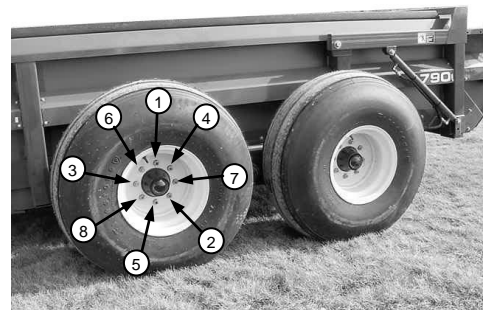

LUBRICATION & MAINTENANCE

LUBRICATE WALKING BEAM PIVOTS

1. Place a jack under the spreader main frame.
2. Raise spreader enough to relieve weight from walking beam.
3. Lubricate grease fitting (A) with Moly High Temperature/Extreme Pressure Grease.

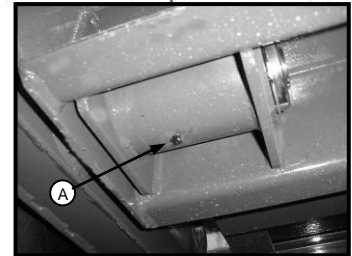
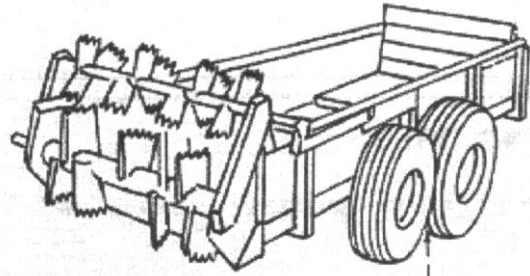

CLEAN AND REPACK WHEEL BEARINGS

Disassemble and clean parts in solvent. Pack bearings (B) with grease. Reassemble and tighten nut (F) until slight drag is felt when wheel is turned. Back nut off to insert cotter pin (G) in first hole.

- A- Seal
- B- Bearing Cone
- C- Bearing Cup
- D- Hub

- E- Washer
- F- Slotted Nut
- G- Cotter Pin

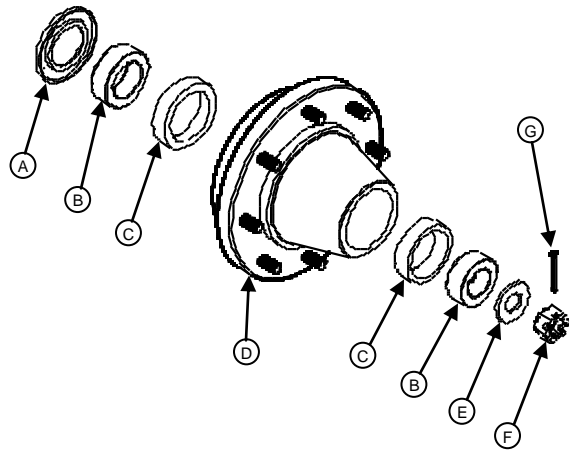

LUBRICATION & MAINTENANCE

ADJUSTING DRIVE CHAIN TENSION

1. Adjust idler (A) clockwise so deflection at midspan (B) is 5/8 in. when 5-10 lb force is applied.

To help prevent idler from loosening, contact surface between idler and hardware must be free of oil and grease. Idler may be relocated to one of three adjustment holes. Position idler to keep longest side against chain.

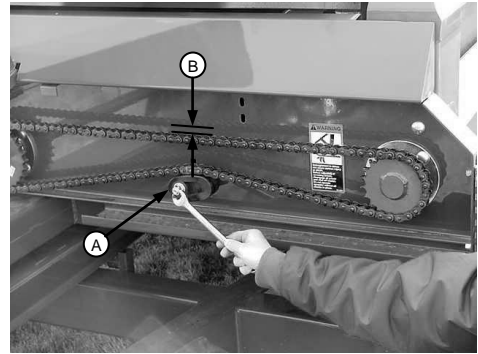

ADJUST INTERM. BEATER DRIVE CHAIN, MODEL 1190

Adjust idler (A) clockwise so that deflection at midspan (B) is 5/8 in. when 5-10 lb force is applied.

To help prevent idler from loosening, contact surface between idler and hardware must be free of oil and grease. Slide idler rearward in slotted hole to keep longest side against chain.

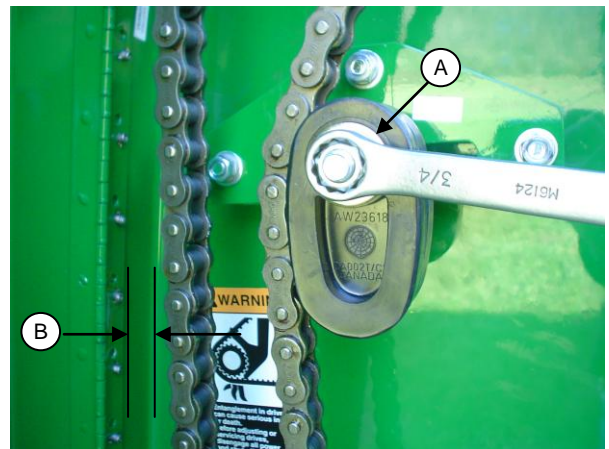

ADJUST UPPER BEATER DRIVE CHAIN

Adjust idler (A) clockwise so that deflection at midspan (B) is 5/8 in. when 5-10 lb force is applied.

To help prevent idler from loosening, contact surface between idler and hardware must be free of oil and grease. Slide idler rearward in slotted hole to keep longest side against chain.

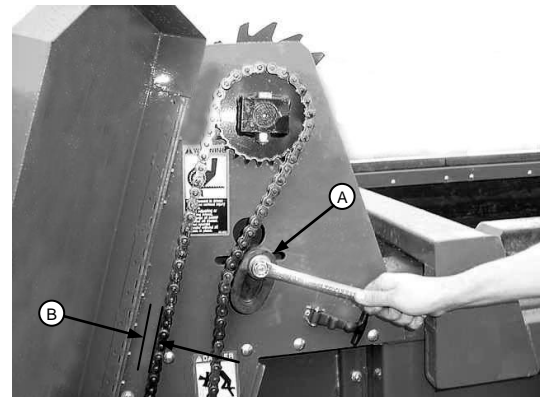

LUBRICATION & MAINTENANCE

MAINTAINING SLIP CLUTCH, WALTERSHIED

The clutch is preset and does not require adjustment.

Before initial operation and after long periods of inactivity, the clutch must be slipped to prevent the friction plates from sticking.

See Slipping the Clutch in the Preparing the Spreader section for instructions.



ADJUST SLIDING FLOOR/MOVING PANEL SEALS

The seals on the moving panel at (A) and sliding floor at (B) are adjustable.

Properly adjusted seals will minimize leakage and ensure a clean wiping action on the sides and floor.

Inspect adjust, or replace seals as necessary.

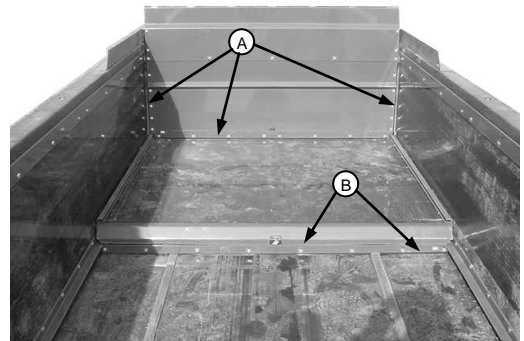

SPECIFICATIONS

MODEL 490

Tractor Size (Minimum)	60 hp PTO
Weight Spreader, Complete with Implement tires and all Attachments	3360
Load Capacity	13000 lb
Volume Capacity	
Struck Level	147 cu. ft.
Heaped Load (Single Beater)	508 cu. ft.
Heaped Load (Upper Beater)	604 cu. ft.
Beater Speed	
Upper	294 rpm
Lower	337 rpm
Unloading Speed	0-16 ft/min Infinitely Variable
Driveline	Shielded 1000 rpm
Attachments	Control For Fender or ROPS Open Center Valve With Control Upper Beater Endgate Slurrypan
(Specifications and design subject to change without notice)	

SPECIFICATIONS

MODEL 490

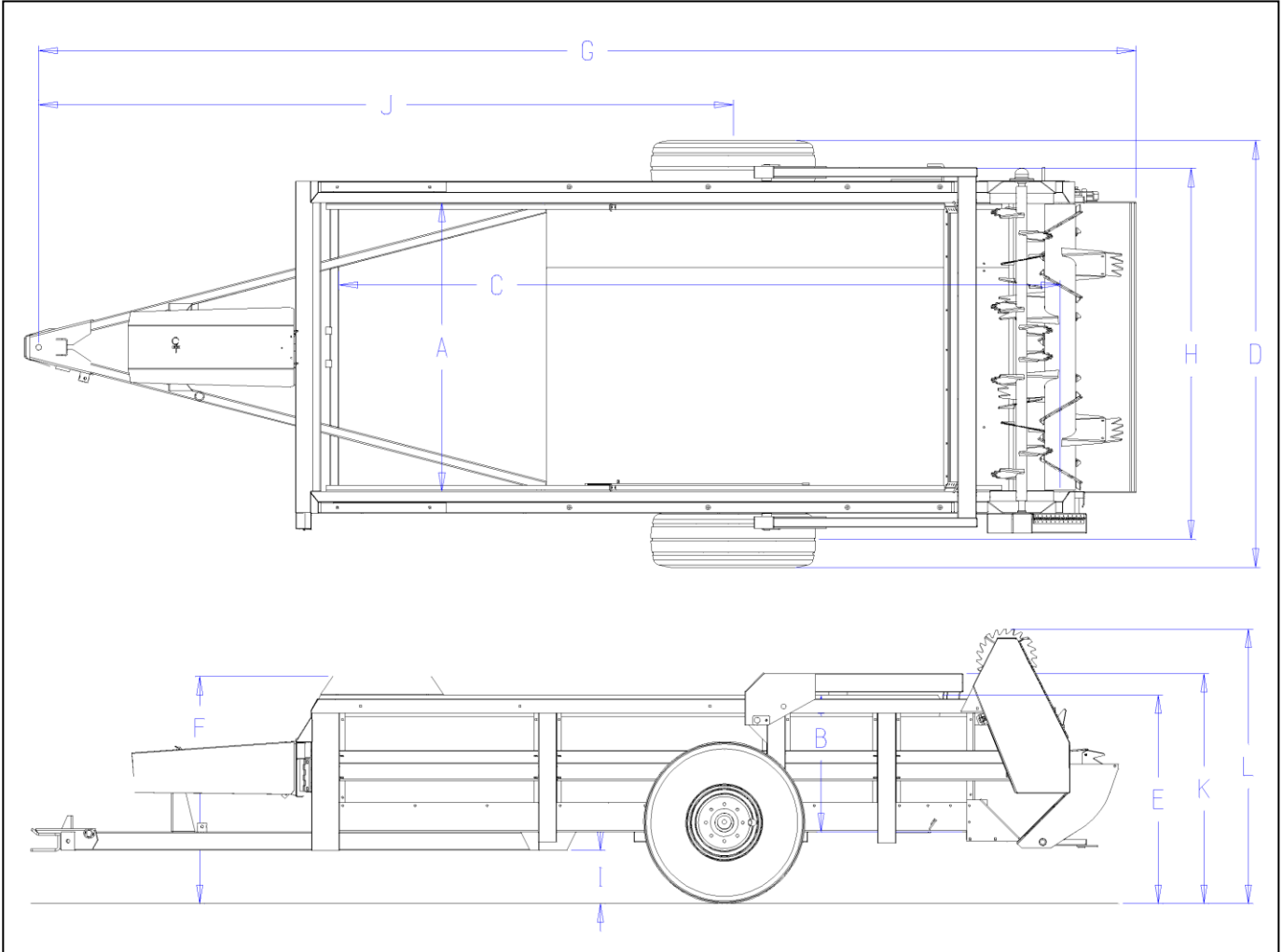

DIMENSIONS*

A- 61.5 in.	E- 47.0 in.	G- 232.0 in.	J- 145.0 in.
B- 34.5 in.	E- 48.0 in.**	H- 97.0 in.	K- 51.5 in.
C- 158.0 in.	F- 51.5 in.	H- 86.0 in.**	K- 52.5 in.**
D- 108.0 in.	F- 52.5 in**	I- 14.0 in.	L- 60.0 in.
D- 97.0 in.**			L- 61.0 in.**

* For spreader equipped with 16.5 x 16.1 Implement tires.

** For spreader equipped with 11R 22.5 recapped truck tires.

(Specifications and design subject to change without notice)

SPECIFICATIONS

MODEL 790

Tractor Size (Minimum)	100 hp PTO
Weight Spreader, Complete with Implement tires and all Attachments	6640 lb
Load Capacity	22600 lb
Volume Capacity	
Struck Level	243 cu. ft.
Heaped Load (Single Beater)	341 cu. ft.
Heaped Load (Upper Beater)	446 cu. ft.
Beater Speed	
Upper	294 rpm
Lower	337 rpm
Unloading Speed	0-16 ft/min Infinitely Variable
Driveline	Shielded 540 rpm Shielded 1000 rpm
Attachments	Control For Fender or ROPS Open Center Valve With Control Upper Beater Endgate Slurrypan
(Specifications and design subject to change without notice)	

SPECIFICATIONS

MODEL 790

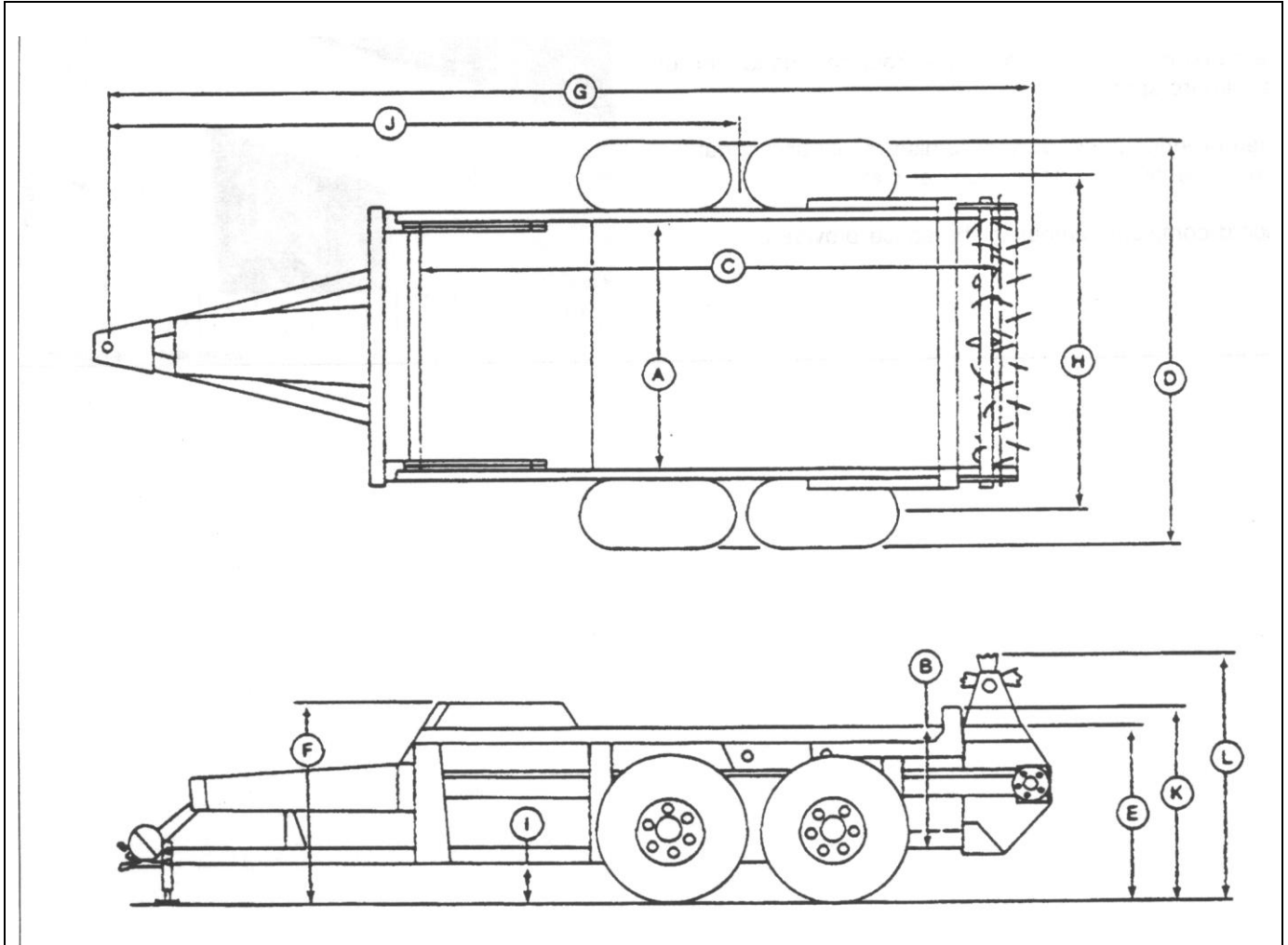

DIMENSIONS*

A- 71.0 in.	E- 52.0 in.	G- 292.0 in.	J- 190.0 in.
B- 31.5 in.	E- 51.0 in.**	H- 105.5 in.	K- 53.0 in.
C- 193.0 in.	F- 62.0 in.	H- 94.5 in.**	K- 54.0 in.**
D- 121.5 in.	F- 63.0 in.**	I- 13.0 in.	L- 69.5 in.
D- 110.5 in.**			L- 70.5 in.**

* For spreader equipped with 16.5 x 16.1 Implement tires.

** For spreader equipped with 11R 22.5 recapped truck tires.

(Specifications and design subject to change without notice)

SPECIFICATIONS

MODEL 1190

Tractor Size (Minimum)	160 hp PTO
Weight Spreader, Complete with Implement tires and all Attachments	9480 lb
Load Capacity	33200 lb
Volume Capacity	
Struck Level	435 cu. ft.
Heaped Load (Single Beater)	508 cu. ft.
Heaped Load (Upper Beater)	604 cu. ft.
Beater Speed	
Upper	294 rpm
Lower	337 rpm
Unloading Speed	0-16 ft/min Infinitely Variable
Driveline	Shielded 1000 rpm
Attachments	Control For Fender or ROPS Open Center Valve With Control Upper Beater Endgate Slurrypan
(Specifications and design subject to change without notice)	

SPECIFICATIONS

MODEL 1190

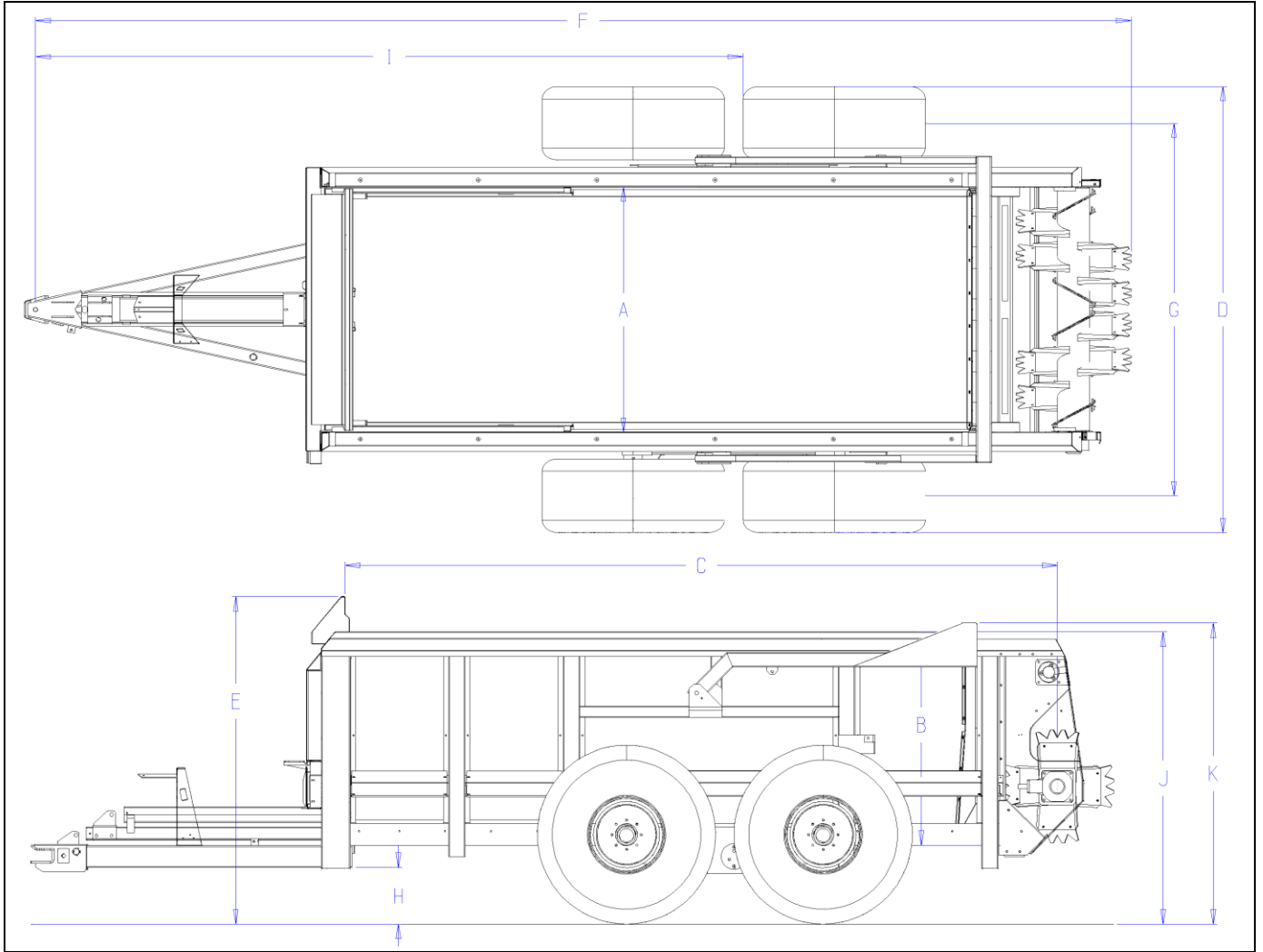

DIMENSIONS*

A- 71.0 in.	D- 128.5 in.	G- 107.0 in.	J- 79.0 in.
B- 58.0 in.	D- 118.5 in.	G- 97.0 in.	J- 77.0 in.
C- 193.5 in.	E- 89.0 in.	H- 15.0 in.	K- 82.0 in.
	F- 292.5 in.	I- 188.0 in.	K- 80.0 in.

* For spreader equipped with 550/60 – 22.5 Implement tires.

** For spreader equipped with 425/65 R 22.5 Recapped truck tires.

(Specifications and design subject to change without notice)