



pikrite

VACUUM TANK

PARTS CATALOG

3rd Edition

WWW.PIKRITE.COM | (800) 326-9763



MISSION STATEMENT

Pik Rite, Inc. is a designer and manufacturer of innovative, quality-built equipment. Pik Rite, Inc. is committed to providing its employees with the best opportunities possible to foster growth in both their personal and work skills, while meeting customer needs and desires by supplying functional and fairly-priced products.

All terms and conditions of sale in this catalog are subject to change without prior notice. The buyer agrees to all terms and conditions of seller upon placement of any and all purchase orders.

In the event of price error, Pik Rite, Inc. reserves the right to charge the correct price. Due to unforeseeable market fluctuation, prices are subject to change without notice.

Order today by calling 800-326-9763 to speak with one of our sales representatives.

You can now pay by cash, check or major credit card.
Standard shipping via FedEx unless otherwise requested.

TABLE OF CONTENTS

Pumps 4

VACUUM PUMP SPECIFICATIONS | VACUUM PUMPS | ROTARY LOBE BLOWERS | VANE PUMP FLUSHING KIT & FLUID | PUMP REBUILD KITS | VACUUM PUMP OIL | COUPLINGS | 3-SHAFT GEARBOXES | ALUMINUM COUPLINGS | ALUMINUM COUPLING ACCESSORIES

Valves 17

BRASS PRESSURE VALVES | BRASS VACUUM RELIEF VALVES | BRASS BALL VALVES | BRASS PISTON VALVES | BRASS LEVER VALVES | BUTTERFLY VALVES

Manways 20

12"-36" MANWAYS (ALUMINUM, STEEL & STAINLESS STEEL) | HATCHES | MANWAY PARTS

Vacuum System Components 22

MUFFLERS & ACCESSORIES | PRIMARY & SECONDARY SHUTOFFS | SHUTOFF PARTS | FINAL FILTERS

Level Indicators 25

SIGHT TUBES | SIGHT EYES | SIGHT EYE REPLACEMENT KIT | LOAD LEVEL INDICATORS | SEELEVEL ANNIHILATOR

Safety 27

PRESSURE GAUGES | VACUUM/PRESSURE SNUBBER | TRUCK LIGHTS | HEATED VALVE JACKETS | ELECTRIC HOT BLOCKS | TOOLBOXES | BACK-UP CAMERAS | GROUNDING REELS | SAFETY LOCKS | SAFETY BUMPERS

VACUUM PUMP SPECIFICATIONS

Pump Description	CFM Free	CFM @18"	CFM @10 PSI	Rec. Speed	Max. Speed	Vac. Cont.	HP	Weight	Hose Input	Hose Output
Fruitland RCF370	275	259	-	1400	1450	18	16	385	3	3
Fruitland RCF500	350	320	-	1300	1400	18	23	450	3	3
Fruitland RCF870	512	460	-	1400	1400	21	-	575	4	4
Jurop PN58	230	205	-	1000	1300	18	9	225	3	3
Jurop PN106	388	324	-	1100	1300	18	18.5	315	3	3
Jurop PN84	317	252	-	1100	1300	18	15	254	3	3
Jurop PNR102	360	332	-	950	1300	18	22	381	3	3
Jurop PN122	430	395	-	950	1300	18	26	419	4	4
Jurop PNR142	501	452	-	950	1200	18	28	562	4	4
Jurop LC300	300	226	-	1100	1300	-	17	452	3	3
Jurop LC420	425	324	-	1100	1300	-	23	485	3	3
Jurop LC580	562	557	-	1000	1200	25	23	512	4	4
Jurop PR150	529	506	-	1000	1200	24	38	761	4	4
Jurop PR200	735	712	-	1000	1200	24	53	981	4	4
Jurop PR250	911	865	-	1000	1100	24	65	1168	6	6
Jurop R260	363	304	-	1050	1200	18	18	397	3	3
Masport HXL2V	75	55	53	1425	1750	20	3.4	96	1.5	1.5
Masport HXL3V	112	82	79	1425	1750	20	5.8	110	1.5	1.5
Masport HXL4V	156	115	109	1225	1400	20	7.7	167	1.5	1.5
Masport HXL75V	230	152	168	1100	1250	20	12.1	229	2.5	2.5
Masport HXL75WV	230	152	160	1100	1275	25	12.5	260	2.5	2.5
Masport HXL15V	350	225	242	1100	1275	20	17.4	313	3	3
Masport HXL15WV	350	225	242	1100	1275	25	17.5	349	3	3
Masport HXL400WV	400	300	307	1100	1275	25	24	450	3	3
Masport VK650	343	250	251	1200	1400	23	26	-	3	3
Robuschi DV45	494	332	350	4200	5000	25	26	213	3	3
Robuschi DV65	912	694	-	4200	4800	25	52	353	4	4
Moro AC3	247	194	e252	1000	1100	18	13	287	3	3
Moro AC4	318	247	e323	1000	1100	18	15	309	3	3
Moro PM80	350	260	330	1000	1100	18	15	401	3	3
Moro PM100	460	370	440	1450	1500	18	22	480	4	4
NVE 304	210	-	-	1250	1400	18	13.5	179	2	2
NVE 607	290	260	244	1250	1500	18	24	470	3	3
NVE 866	452	381	389	1000	1150	18	24	515	4	4
NVE 4307	559	356	423	3500	4000	25	25.5	371	4	4
NVE 4310	931	763	733	4000	4500	25	51.9	449	4	4
Wittig RFL100	412	376	e395	1450	1500	24	36	375	4	4
Wittig RFW150	506	482	e500	1450	1500	24	48	485	4	4
Wittig RFW200	730	694	e705	1450	1500	24	42/66	617	4	4
Wittig RFW260	942	906	e915	1450	1500	24	86	794	4	4



Specifications	RCF 370	RCF 500	RCF 870
Approximate Air Flow	259 CFM	320 CFM	460 CFM
Maximum Vacuum	28.5" Hg	28.5" Hg	28.5" Hg
Power Required at 27" Hg	19 BHP	23 BHP	-
Pressures to	35 PSI	35 PSI	30 PSI
Power Required at Max. Pressure	36 BHP	44 BHP	44 BHP
Size of Hoses	3"	3"	4"
Maximum Operating Speed	1400 RPM	1400 RPM	1400 RPM
Lubrication (Oil Pump)	Automatic	Automatic	Automatic
Vanes	8	8	8
Fan Cooling Continuous Duty	Yes	Yes	Yes
Approximate Net Pump Weight	385 lbs.	450 lbs.	575 lbs.



RCF 870



RCF 370



RCF 500

OTHER PUMPS, PUMP SYSTEMS AND ENGINE
DRIVEN SYSTEMS ARE AVAILABLE.

Masport®



WHILE HAVING NUMEROUS FEATURES,
OUR PUMPS BOAST:

- Solid 6-Vane Rotor Design
- Liquid Cooled Design
- Mechanical Oil Pump
- End Thrust Protection
- Double End Shaft
- Integral Valve
- Heavy Duty Bearings
- Kevlar Vanes (heat stabilized and machined with exact tolerances for superior ruggedness and durability)

PERFORMANCE DATA FOR THE 400WV MASPORT PUMP

PERFORMANCE DATA-VACUUM

Pump RPM	Displacement CFM	SCFM and ACFM at Vacuum											Maximum Vacuum - "Hg	
		5	10	15	18	20	22	24	25	26	27	Continuous	Intermittent	
1100	345	SCFM	269	204	150	120	100	80	57	47	35	25	25	27
		ACFM	323	306	300	300	300	300	300	282	263	250		
1275	400	SCFM	312	237	175	140	117	93	66	54	41	29	25	27
		ACFM	374	356	350	350	350	350	350	324	308	290		

PERFORMANCE DATA-PRESSURE

Pump RPM	Displacement CFM	SCFM at PSIG							Maximum Pressure - PSIG	
		5	10	15	18	20	25	30	Continuous	Intermittent
1100	345	321	307	292	275	258	243	224	20	30
1275	400	372	356	339	319	300	282	264	20	30

HORSEPOWER REQUIRED AT PSIG

Pump RPM	PSIG					
	5	10	15	20	25	30
1100	20	24	28	32	35	42
1275	24	28	33	38	42	50

HORSEPOWER REQUIRED AT "HG

Pump RPM	Vacuum "Hg		
	15	20	27
1100	15	16.5	17
1275	17.7	19.5	20.1

OTHER PUMPS, PUMP SYSTEMS AND ENGINE
DRIVEN SYSTEMS ARE AVAILABLE.



ROTARY LOBE BLOWERS

MAIN BLOWER FEATURES:

- Vacuum rate up to 93% (blank off) - 28" Hg and 90% - 27" Hg continuous
- Nominal capacity from 840 to 10.500 m³ /h - from 494 CFM to 6200 CFM
- Gases and vapors can be handled
- Lack of sliding parts, reduces wear
- Safe operation, environmentally friendly
- No oil mist
- Multiple blower systems available, including the DV45, DV65 and DV85

Supported by
Masport

USED IN THE FOLLOWING APPLICATIONS:

- Vacuum trucks handling wet and/or dry waste (Industry, municipalities, etc.)
- Pneumatic Conveying (Ash transport, chemicals, pharmaceuticals industry, etc.)
- Central Vacuum Systems (Packaging, vacuum cleaning, etc.)
- Deaeration Plants (Plastic extrusion, brick production, etc)



Helical gears provide near noiseless smooth and synchronized operation.

Heavy duty rotor and shaft assemblies safely allow operation at higher rpm's providing outstanding performance.

Labyrinth piston ring provides low wear.

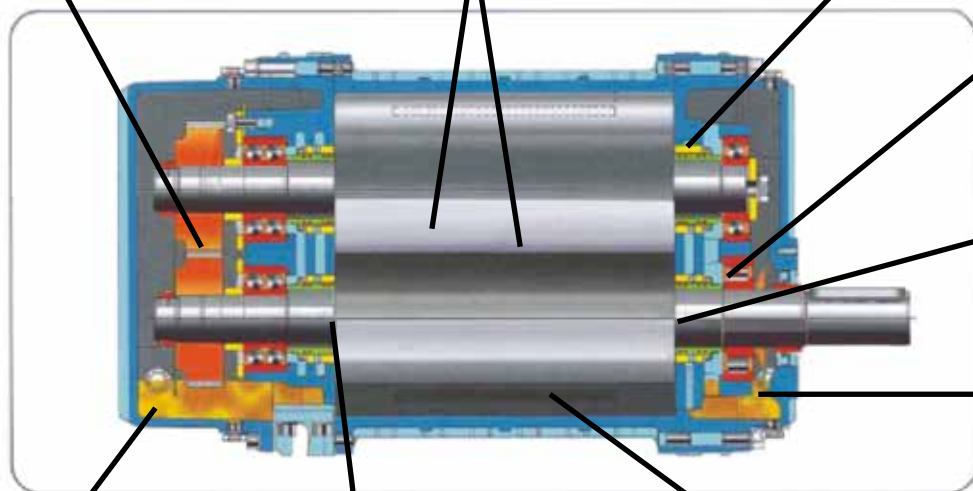

Heavy duty bearing for belt or gear transmission.

Heavy duty bearings allow greater flexibility setting up belt or close coupled transmission.

Double ended oil bath lubrication ensures long bearing life.

Double ended oil bath lubrication ensures long bearing life.

Patent tri (3) lobe rotors with ROBUSCHI high performance profile (low pulse).

Patent air injection nozzle ensures cool operation under all vacuum conditions.

NVE

National Vacuum Equipment, Inc.



304



607

866

304 Challenger Specifications	
Air Flow @ Free Air	210 CFM
Max Intermittent Vacuum	27" Hg
Max Intermittent Pressure	20 PSI
Operating Speed	1000-1400 RPM
Porting Size	2" (optional 1 1/2")
Shaft Size (1/4" Key)	1 1/4"
Approximate Weight	179 lbs.

Superior Cooling for Extended Operations in Severe Conditions • Heavy Duty Roller Bearings • 3-Point Oiling System • Precision-Pinned End Plates • Slotted End Plate Bolt Holes for Crash Protection • Vane Wear Inspection Port • Exhaust Gas Temperature Gauge • Air-Injected Ballast Port Cooling for Extended Use In Deep Vacuum • Diesel Flush Port • High-Strength Ductile Iron Housing

		Pressure (PSI)					Free Flow	Inches of Vacuum (Hg)					
	RPM		20	15	10	5	0	5	10	15	20	25	27
607	1500	HP	34	32	29	27	23	23	22	21	20	19	19
		CFM	282	291	301	331	357	348	338	331	310	282	244
	1250	HP	29	27	24	23	20	20	19	16	15	14	14
		CFM	229	237	244	269	290	282	275	269	252	229	198
	1000	HP	25	23	20	18	15	15	14	14	13	12	12
		CFM	178	184	190	209	226	220	214	209	196	178	155
866	1150	HP	43	36	27	25	18	21	23	23	24	26	29
		CFM	431	438	447	457	506	470	543	440	438	425	351
	1000	HP	38	32	24	20	15	18	20	21	22	14	14
		CFM	375	381	389	398	452	409	394	390	381	370	306
	800	HP	32	25	19	25	13	14	16	17	18	19	21
		CFM	319	324	331	342	385	348	333	331	324	315	242

NVE ROTARY LOBE BLOWERS



NVE 4307

- Ballast Port Manifold
- Maximum Air Flow 535 CFM
- 4" Hose Barbed Adjustable Porting (for intake & exhaust)
- Recommended Operating Range 2700-4000 RPM
- Integral Final Filter with Easy Access for Cleaning

		Inches of Vacuum (Hg)				Pressure (PSI)
R.P.M.		0	18	24	27	10
2000	HP	2.0	12.8	16.4	-	14.2
	CFM	280	77	-	-	143
2500	HP	2.5	16.0	20.5	-	17.7
	CFM	349	147	17	-	213
3500	HP	3.5	22.4	28.7	31.8	24.8
	CFM	489	286	157	-	353
4000	HP	4.0	25.6	32.8	36.4	28.4
	CFM	559	356	227	57	423

NVE 4310

- Continuous Duty Performance at Maximum Vacuum
- Ballast Port Manifold
- Tri-lobe Design with Precision Machining
- Range of Airflow Performance Available to Accommodate Available Power
- Oil-less Operation

		Inches of Vacuum (Hg)				Pressure (PSI)
R.P.M.		0	18	24	27	10
2400	HP	2	17.8	23.1	-	24.8
	CFM	500	407	255	-	324
4000	HP	4	35.6	46.1	51.4	39.7
	CFM	826	661	528	182	631
4500	HP	4.5	40	51.9	57.8	44.7
	CFM	931	763	660	270	733

OTHER PUMPS, PUMP SYSTEMS AND ENGINE DRIVEN SYSTEMS ARE AVAILABLE.

Jurop

NORTH AMERICA



PN-58



R-260



LC-420

Specifications	PN-58	R-260 (1 3/8 shaft)	LC-420 (1 3/8 shaft)
RPM Range	900-1300	900-1200	1000-13000
Max. Vacuum	27.6 - 92%	27.6" - 92%	27" - 90%
CFM at Free Air	230	363	425
CFM at 18"	205	304	324
Max. Intermittent Pressure	21 PSI	21 PSI	29 PSI
HP	9	18	23
Noise Level at 18"	77 db	84 db	75-78 db
Oil Tank Capacity	2.44 qts.	2.44 qts.	2.12 qts.
Net Weight	255 lbs.	397 lbs.	462 lbs.
Recommended Oil	ISO 150	ISO 150	ISO 150

OTHER PUMPS, PUMP SYSTEMS AND ENGINE
DRIVEN SYSTEMS ARE AVAILABLE.



Features:

- Large, open ported manifold, design reduces noise and air friction
- High performance, kevlar vanes with visual inspection ports in casing
- High quality Viton oil seals - longer life than traditional oil seals
- Low rotating speed leads to longer pump life
- Sealed bearings - no grease points
- 29 PSI positive pressure capability
- Direct feed, sealed oiling system

	RPM	Free Air Flow	Performance	Suggested Tank Size	CFM	PSI	Weight	Hose	Cooling
PM80W	1400	417 CFM	312 CFM	2000-4000 gallons	417	29	480 lbs.	3"	Liquid
	1250	372 CFM	279 CFM						
	*1100	328 CFM	245 CFM						
PM110W	1400	630 CFM	554 CFM	2000-6000 gallons	630	29	645 lbs.	3 3/4"	Liquid
	1250	562 CFM	486 CFM						
	*1100	496 CFM	388 CFM						

*Recommended RPM

OTHER PUMPS, PUMP SYSTEMS AND ENGINE DRIVEN SYSTEMS ARE AVAILABLE.



SDS 12



SDS 6



SUPER 6



**Conde HD
VACUUM/PRESSURE
PUMPS**

Specifications	Super 6	SDS 6	SDS 12
Ideal Tank Cap.	300-500 Gal.	500-1000 Gal.	1000-2000 Gal.
CFM	70	115	180
Speed Range	1200-1750 RPM	1200-1750 RPM	1200-1750 RPM
Max. Vacuum	28" Hg Intermittent	28" Hg Intermittent	28" Hg Intermittent
Lubrication	Conde Auto.	Conde Auto.	Conde Auto.
Max. Pressure	20 PSIG	20 PSIG	20 PSIG
Port Size	1-1/4"	1-1/2"	1-1/2"
Shaft Size	1"	1"	1-1/8"
Weight	90 lbs.	115 lbs.	165 lbs.

VANE PUMP FLUSHING KIT & FLUID

Part #	Description
VPA-0003	Pump Flushing Kit
VPA-FF-13900	Flushing Fluid
DC-0080	Flushing Fluid Decal
DC-0081	Tank Decal
VPA-MAS-36002	Tank Oil Cap
VPA-MAS-36001	1 Gal. Tank Reservoir
H4-PL	Hose (Per Foot)
VP-3971	Filter



Kit Parts List: Cap (Lubricator Tank), Lubricator Tank (4 Quarts), Hose (1/4"), Hose Clamp, Pushlock (1/4" Brass), Elbow (1/4" Brass), Flow Restrictor, Bracket Flushing Kit, Nipple (1/4"), Spring Close Ball Valve

PUMP REBUILD KITS

The Pik Rite service department can rebuild or refurbish your pump when it shows signs of excessive wear. We also stock a full line of repair kits if you choose to rebuild or refurbish the pump yourself.

Pik Rite stocks the following pump repair kits:

- Gasket & Seal Kits
- Gasket & Seal Kits with Vanes
- Complete Rebuild Kits with Bearings



VACUUM PUMP OIL



- Specifically formulated for use in vacuum pumps
- Resists foaming and sludge or varnish formation
- Extends life of O-rings and seals
- Excellent anti-wear protection
- Quickly displaces water

**Available Exclusively
from Pik Rite!**

Part #	Description
OIL-12068	1 Gal. Vacuum Pump Oil
OIL-12068D	55 Gal. Drum Vacuum Pump Oil
DC-0075	Pump Oil Decal
VPA-MAS-36001	1 Gal. Tank Reservoir

COUPLINGS

The pump coupling is located between the pump and the gearbox. It is designed as a safety measure in that it will shear in the event of a pump seizure. It protects both the pump and the gearbox.

Part #	Description	Weight
CPLW-916	1" Flange Size 9 with 1/4" Keyway	7 lbs.
CPLW-920	1 1/4" Flange Size 9 with 1/4" Keyway	7.45 lbs.
CPLW-922-2	1 3/8" Flange Size 9 with 5/16" Keyway	6.5 lbs.
CPLW-1020	1 1/4" Flange Size 10 with 1/4" Keyway	13.5 lbs.
CPLW-1022-2	1 3/8" Flange Size 10 with 5/16" Keyway	13.4 lbs.
CPLW-8SJE	Size 8 EPDM Rubber Protection Sleeve	1.4 lbs.
CPLW-9JE	Size 9 EPDM Rubber Protection Sleeve	2.02 lbs.
CPLW-10SJE	Size 10 EPDM Rubber Protection Sleeve	6.7 lbs.



Other sizes are available.

3-SHAFT GEARBOXES

This heavy duty constructed 3-shaft gearbox is made to accommodate CW or CCW rotation of the vacuum pump. It features bi-rotational angle drive, heavy duty gears, and a 1" or 1 1/4" output shaft.



Part #	Description	Weight
GBX-20-3	3-Shaft Gearbox 1-1 Ratio 400 Series with 1 1/4" Shaft and 1/4" Keyway	29 lbs.
GBX-20-3115	3-Shaft Gearbox 1-1.5 Ratio 400 Series with 1 1/4" Shaft and 1/4" Keyway	29 lbs.
GBX-20-321	3-Shaft Gearbox 2-1 Ratio 400 Series with 1 1/4" Shaft and 1/4" Keyway	29 lbs.
GBX-16-3	3-Shaft Gearbox 1-1 Ratio 200 Series with 1" Shaft	13 lbs.
GBX-16-3151	3-Shaft Gearbox 1-1.5 Ratio 200 Series with 1" Shaft	13 lbs.
GBX-16-321	3-Shaft Gearbox 2-1 Ratio 200 Series with 1" Shaft	13 lbs.

ALUMINUM COUPLINGS



Size	Part #
2"	CPL-2M-2F
3"	CPL-3M-3F
4"	CPL-4M-4F
6"	CPL-6M-6F

Male w/ Female Threads



Size	Part #
2"	CPL-2M-2M
3"	CPL-3M-3M
4"	CPL-4M-4M
6"	CPL-6M-6M

Male w/ Male Threads



Size	Part #
2"	CPL-2F-2M
3"	CPL-3F-3M
4"	CPL-4F-4M

Female w/Male Threads



Size	Part #
2"	CPL-2-CP
3"	CPL-3-CP
4"	CPL-4-CP
6"	CPL-6-CP

Female Dust Cap



Size	Part #
2"	CPL-2F-H
3"	CPL-3F-H
4"	CPL-4F-H
6"	CPL-6F-H

Female w/ Hose Shank



Size	Part #
2"	CPL-2M-PL
3"	CPL-3M-PL
4"	CPL-4M-PL
6"	CPL-6M-PL

Male Dust Plug



Size	Part #
2"	CPL-2F-2F
3"	CPL-3F-3F
4"	CPL-4F-4F
6"	CPL-6F-6F

Female w/ Female Threads



Size	Part #
3" x 2"	CPL-3F-2M
4" x 2"	CPL-4F-2M
4" x 3"	CPL-4F-3M
6" x 4"	CPL-6F-4M

Female x Male Reducer



Size	Part #
2"	CPL-2M-H
3"	CPL-3M-H
4"	CPL-4M-H
6"	CPL-6M-H

Male w/ Hose Shank



Size	Part #
1"	AN-16-HS
2"	AN-32-HS
3"	AN-48-HS
4"	AN-64-HS

Combination Nipple
Shank x Male NPT

ALUMINUM COUPLING ACCESSORIES



Size	Part #
2"	PH-02-WHS
3"	PH-03-WHS
4"	PH-04-WHS
6"	PH-06-WHS

Hose Mender
Shank x Shank



Size	Part #
2"	CPL-2-G
3"	CPL-3-G
4"	CPL-4-G
6"	CPL-6-G

Replacement Gasket



Size	Part #
1.5"	PH-150-WH
2"	PH-02-WH
3"	PH-03-WH
4"	PH-04-WH

Weldable Hose Barb



Size	Part #
2"	CPLA-1085-0001
3"	CPLA-1086-000
4"	CPLA-1086-000
6"	CPLA-1087-000

Replacement Cam
Lock Arm



Size	Part #
2"	CL-201
3"	CL-375
4"	CL-400
6"	CL-606

Super Heavy Duty T-Bolt
Hose Clamp



Size	Part # Alum.	Part # Steel
3"	FLA-03-1	FLA-03-3
4"	FLA-04-4	FLA-04-2
6"	FLA-06-6	FLA-06-22

TTMA Flange w/ MPT



Size	Part #
2 1/2"	CL-B10
3 1/2"	CL-B16
4 1/2"	CL-B24
8"	CL-B32

Clamps



Size	Part #
3"	FL-03-4
4"	FL-04-4
6"	FL-06-3

Weldable TTMA Flange



Size	Part #
2"	STR-R200
4"	STR-R400

Round Hole Strainer



Size	Part #
3"	FLG-05
4"	FLG-04
6"	FLG-03

TTMA Gasket



Size	Part #
5/8"	TL-BCLAMP

Bandit Tool

BRASS PRESSURE VALVES



- Durable Brass Construction
- Fully Adjustable
- Pressure Range from 155 to 300 CFM

Part #	Description	Weight
PRV-150	1 1/2" Brass Pressure Valve - (230 CFM)	2 lbs.
PRV-200	2" Brass Pressure Valve - (300 CFM)	3 lbs.
PRVA-200	Replacement Ring	

BRASS VACUUM RELIEF VALVES



- Durable Brass Construction
- Available in 1 1/2" Size

Part #	Description	Weight
VRV-150	1 1/2" Brass Vacuum Relief Valve - (370 CFM)	1 lb.

FOR DETAILED INSTRUCTIONS ON SETTING YOUR VACUUM OR PRESSURE RELIEF VALVE, GO TO WWW.PIKRITE.COM/SETTINGINSTRUCTIONS.

BRASS BALL VALVES

Part #	Description	Weight
VLV-1-B	1" Valve w/ Female NPT x Female NPT	1.5 lbs
VLV-200B	2" Valve w/ Female NPT x Female NPT	8 lbs.
VLV-3B	3" Valve w/ Female NPT x Female NPT	11 lbs.
VLV-4B	4" Valve w/ Female NPT x Female NPT	20 lbs.



BRASS PISTON VALVES



Part #	Description	Weight
VLV-4-N	4" Piston Valve w/ Female NPT x Female NPT	13 lbs.
VLV-4-NA	4" Piston Valve w/ Female NPT x Female NPT w/ Air Cylinder	21 lbs.
VLV-6-N	6" Piston Valve w/ Female NPT x Female NPT	20 lbs.
VLV-6-NNA	6" Piston Valve Female NPT x Female NPT w/ Air Cylinder	29 lbs.
VLV-4-4F	4" Piston Valve w/ 4-Bolt Flange x 4-Bolt Flange	13 lbs.
VLV-4-4FA	4" Piston Valve 4-Bolt Flange x 4-Bolt Flange w/ Air Cylinder	21 lbs.
VLV-4-4F-H	4" Piston Valve 4-Bolt Flange x 4-Bolt Flange w/ Hydraulic Cylinder	21 lbs.
VLV-6-4F	6" Piston Valve w/ 4-Bolt Flange x 4-Bolt Flange	19 lbs.
VLV-6-4FA	6" Piston Valve 4-Bolt Flange x 4-Bolt Flange w/ Air Cylinder	28 lbs.
VLV-6-4FH	6" Piston Valve 4-Bolt Flange x 4-Bolt Flange w/ Hydraulic Cylinder	28 lbs.

BRASS LEVER VALVES

Part #	Description	Weight
VLV-2	2" Valve w/ Female NPT x Female NPT	4 lbs.
VLV-3	3" Valve w/ Female NPT x Female NPT	9 lbs.
VLV-4	4" Valve w/ Female NPT x Female NPT	15 lbs.
VLV-6-6L	6" Valve w/ Female NPT x Female NPT	23 lbs.



BUTTERFLY VALVES

Part #	Description	Weight
VLV-3-BFY	3" Butterfly Valve, Nickel Plated Disk, Cast Iron Body	9 lbs.
VLV-4-BFY	4" Butterfly Valve, Nickel Plated Disk, Cast Iron Body	13 lbs.
VLV-6-BFY	6" Butterfly Valve, Nickel Plated Disk, Cast Iron Body	19 lbs.
VLV-3-0010	Handle for 3" Butterfly Valve	1.5 lbs.
VLV-4-0010	Handle for 4" Butterfly Valve	1.5 lbs.
VLV-6-0010	Handle for 6" Butterfly Valve	1.5 lbs.

HATCHES & MANWAYS

12" Hatch



- Gasket in the lid design
- Weldable base is 1/4" steel, stainless steel or aluminum
- Standard neck lengths of 6" or 12"
- Unpainted

17" Manway



- Gasket in the lid design
- Weldable base is 1/4" steel
- Standard neck lengths of 6" or 12"
- Unpainted

20" Manway



- Gasket in the lid design
- Weldable base is 1/4" steel
- Standard neck lengths of 6" or 12"
- Unpainted

21" Manway



- Gasket in the lid design
- Standard neck lengths of 6" or 12"
- Right or left hing models
- 1/4" or 3/16" steel construction
- Unpainted

36" Manway



- Gasket in the lid design
- Weldable base is 1/4" steel
- Standard neck lengths of 6" or 12"
- Unpainted

20" Aluminum
Manway



- Gasket in the lid design
- Standard neck length of 6"
- Neck available in steel, stainless steel or aluminum
- Unpainted

HATCHES & MANWAYS

Part #	Description	Weight	Features
12" Hatch - 3 Wing Nut			
MW-12-2	12" Hatch w/ 6" Steel Neck - 1/4" Base	40 lbs.	<ul style="list-style-type: none"> Gasket in the lid design Weldable base is 1/4" steel, stainless steel or aluminum Standard neck lengths of 6" or 12" available in steel, stainless steel or aluminum
1010-0054	12" Hatch w/ 12" Steel Neck - 1/4" Base	58 lbs.	
1010-0056	12" Stainless Hatch w/ 6" Stainless Steel Neck, 304 - 1/4" Base	40 lbs.	
1010-0057	12" Stainless Hatch w/ 12" Stainless Steel Neck, 304 - 1/4" Base	58 lbs.	
1010-0058	12" Stainless Hatch w/ 6" Aluminum Neck, 6061 - 1/4" Base	28 lbs.	
17" Manway - 4 Wing Nut			
MW-17-1	17" Manway w/ 6" Neck, 4 Wing Nut Lid - 1/4" Base	56 lbs.	<ul style="list-style-type: none"> Gasket in the lid design Weldable base is 1/4" steel Standard neck lengths of 6" or 12"
1010-0064	17" Manway w/ 12" Neck, 4 Wing Nut Lid - 1/4" Base	82 lbs.	
20" Manway - 5 or 6 Wing Nut			
MW-20-1	20" Manway w/ 6" Neck, 6 Wing Nut Lid - 1/4" Base	74 lbs.	<ul style="list-style-type: none"> Gasket in the lid design Weldable base is 1/4" steel Standard neck lengths of 6" or 12"
1010-7400	20" Manway w/ 12" Neck, 6 Wing Nut Lid - 1/4" Base	100 lbs.	
MW-20-2	20" Manway w/ 6" Neck, 5 Wing Nut Lid - LHH - 1/4" Base	73 lbs.	
21" Manway - 6 Wing Nut			
MW-21-6	21" Manway w/ 6" x 1/4" Neck, 6 Wing Nut Lid	95 lbs.	<ul style="list-style-type: none"> Gasket in the lid design 3/16 Steel construction Right or left hinge models
1010-0021	21" Manway w/ 12" x 1/4" Neck, 6 Wing Nut Lid	113 lbs.	
36" Manway - 8 Wing Nut			
1012-0000	36" Manway w/ 6" Neck, 8 Wing Nut Lid - 1/4" Base	131 lbs.	<ul style="list-style-type: none"> Gasket in the lid design Weldable base is 1/4" steel Standard neck lengths of 6" or 12"
MW-36-1	36" Manway w/ 12" Neck, 8 Wing Nut Lid - 1/4" Base	167 lbs.	
20" Aluminum Manway			
MW-20-2A	20" S.S. Manway w/ 6" Alum. Neck - 1/4" Base	51 lbs.	<ul style="list-style-type: none"> Gasket in the lid design Standard neck lengths of 6" available in steel, stainless steel or aluminum Base is 1/4" stainless steel or aluminum
1010-9010	20" S.S. Manway w/ 12" Alum. Neck - 1/4" Base	60 1/2 lbs.	
MW-20-8SS	20" S.S. Manway w/ 6" S.S. Neck - 1/4" S.S. Base	72 lbs.	
1010-9033	20" S.S. Manway w/ 12" S.S. Neck - 1/4" S.S. Base	99 3/4 lbs.	
20" Aluminum Manway - 6 Cam Levers			
1010-0030	20" Manway w/ 6" Alum. Neck, 6 Cam Lever Lid	40 lbs.	<ul style="list-style-type: none"> Gasket in the lid design Weldable base is 20.38" O.D. Standard neck lengths of 6" available in mild steel, stainless steel or aluminum 6 adjustable cam levers
1010-3012	20" Manway w/ 12" Alum. Neck, 6 Cam Lever Lid	55 lbs.	
1010-0031	20" Manway w/ 6" 304 S.S. Neck, 6 Cam Lever Lid	50 lbs.	
1010-0035	20" Manway w/ 6" Mild Steel Neck, 6 Cam Lever Lid	50 lbs.	
1010-0037	20" Manway w/ 12" Mild Steel Neck, 6 Cam Lever Lid	71 lbs.	



Wing Nut



Clevis Pin



Gasket



Greaseable Wing Nut



Washer

Manway Parts		
MWA-21N	5/8" Zinc Plated Wing Nut	2 lbs.
10100002	Greaseable Wing Nut Assembly	1.57 lbs.
MWA-21W	Zinc Recessed Washer	.188 lbs.
MWA-21B	5/8" x 5" Zinc Plated Eyebolt	.80 lbs.
MWA-21B-SS	S.S. Eyebolt	N/A
MWA-21R	Zinc Plated Roll Pin	.06 lbs.
MWA-HP	Hinge Pin	.44 lbs.
MWA-21P	Clevis Pin	N/A
Replacement Gaskets (in lid)		
MWA-1021	5/8" Square Gasket (per ft.)	.33 lbs.
MWA-20-1	Gasket for 20" Manway	N/A
MWA-1009	Gasket for 21" Manway	2 lbs.
MWA-25-1	Gasket for 25" Manway	2.5 lbs.
MWA-1012-05	Gasket for 36" Manway	3.25 lbs.

MUFFLERS AND ACCESSORIES



Part #	Description
MUF-03-UMD	Muffler, 3" Upright Oil Catch, Dempad
MUF-04-UM	Muffler, 4" Upright Oil Catch, Dempad
MUF-04-101	Muffler, Bottom Half 4" W/ Clamps
MUFA-10-A	Bracket, Muffler Mount, Upright
MUFA-10-B	Mount Pad

Note: Applications can be different; welding and assembly required.



PRIMARY SHUTOFF

12" Primary Shutoff

Part #	Description	Weight
PRI-12-6-3	12" Primary w/ 6" Neck & 3" Opening, 450 CFM	57 lbs.
1014-0012	12" Primary w/ 6" Neck & 4" Opening, 525 CFM	60 lbs.
1014-0015	12" Primary w/ 6" Neck & 6" Threaded Opening, 950 CFM	60 lbs.



- Standard neck length of 6"
- Weldable base is 12.25 O.D.
- Easy access for quick clean out
- Heavy duty zinc plated hardware
- Positive shutoff with 6" or 8" stainless steel ball



12" Low Profile Primary Shutoff

Part #	Description	Weight
PRI-12-6-3L	12" Low Profile Primary Shutoff, 6" Neck w/ 3" Pipe w/ Opening, 450 CFM	60 lbs.
1014-0901	12" Low Profile Primary Shutoff, 6" Neck w/ 3" NPT Threads w/ Opening, 450 CFM	61 lbs.
PRI-12-6-4L	12" Low Profile Primary Shutoff, 6" Neck w/ 4" Pipe w/ Opening, 525 CFM	66 lbs.
1014-0911	12" Low Profile Primary Shutoff, 6" Neck w/ 4" NPT Threads w/ Opening, 525 CFM	67 lbs.
1014-0914	12" Low Profile Primary Shutoff, 6" Neck w/ 4" Pipe w/ Opening Includes 8" & 10" Ball Cage	77 lbs.

SECONDARY SHUTOFF

- Gasket in the lid design
- 3-wing nut easy access
- Tested from 0-400 CFM
- 1" ball drain valve
- Under the catwalk installation
- Dual rear mounting brackets
- 6" stainless steel float ball
- 3" rubber shutoff seat
- Heavy duty ball cage



Part #	Description	Weight
SEC-10-3H	10 Gal. Horizontal Secondary, 3" Opening (375 CFM)	72 lbs.

Other sizes and configurations available

SHUT OFF PARTS

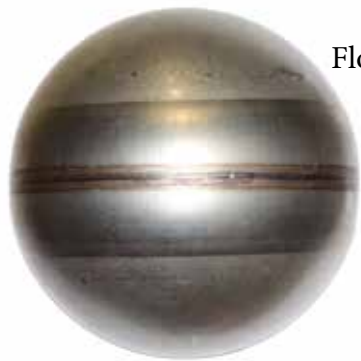

Float Balls



Rubber Seats

Part #	Float Balls	Weight
PRIA-0004	4" Stainless Steel Float Ball	1 lb.
PRIA-0001	6" Stainless Steel Float Ball	3 lbs.
	Rubber Shutoff Ball Seats	
PRIA-0009	3" Rubber Seat (Fits 3" O.D. Pipe w/ Flare)	.5 lbs.
PRIA-0003	3 1/2" Clamp-On Rubber Seats (Fits 3 1/2" O.D. Pipe)	1 lb.
PRIA-0006	4" Rubber Seat (Fits 4 1/2" O.D. Pipe)	2 lbs.



FINAL FILTERS

Part Number: FF-3-3

- 2 wing nut style easy access
- Filter element to prevent airborne debris from entering the pump (extending vacuum pump life)
- Reusable stainless steel 55 mesh wire filter element for high heat application (stops particles down to 0.020 inches)
- Easy access for cleaning

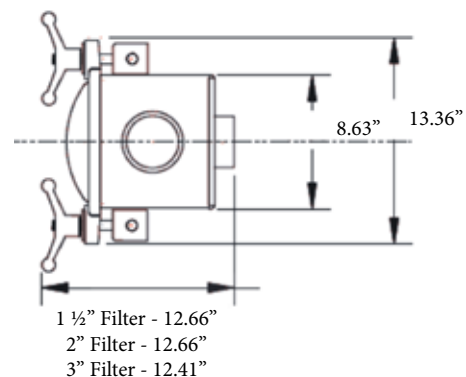
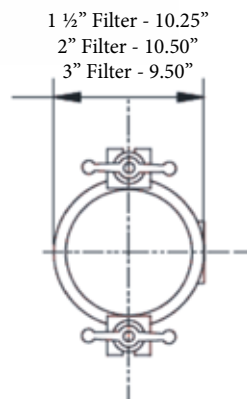

CLEAR POLYCARBONATE SIGHT TUBES



Clear sight tubes provide a full visual fluid level range of your load.

Features Include:

- No Gauges to Read
- Exceptional Durability
- Shutoff Valves at the Top and Bottom
- Easy to Clean
- Ideal for Work Sites that Don't Allow Sight Eyes

Part #	Description
PL-24-PC	Clear Polycarbonate Sight Tube 1 1/2" O.D., 8' Long
PL-32-PC	Clear Polycarbonate Sight Tube 2" O.D., 8' Long

SIGHT EYES



SIGHT EYE REPLACEMENT KIT

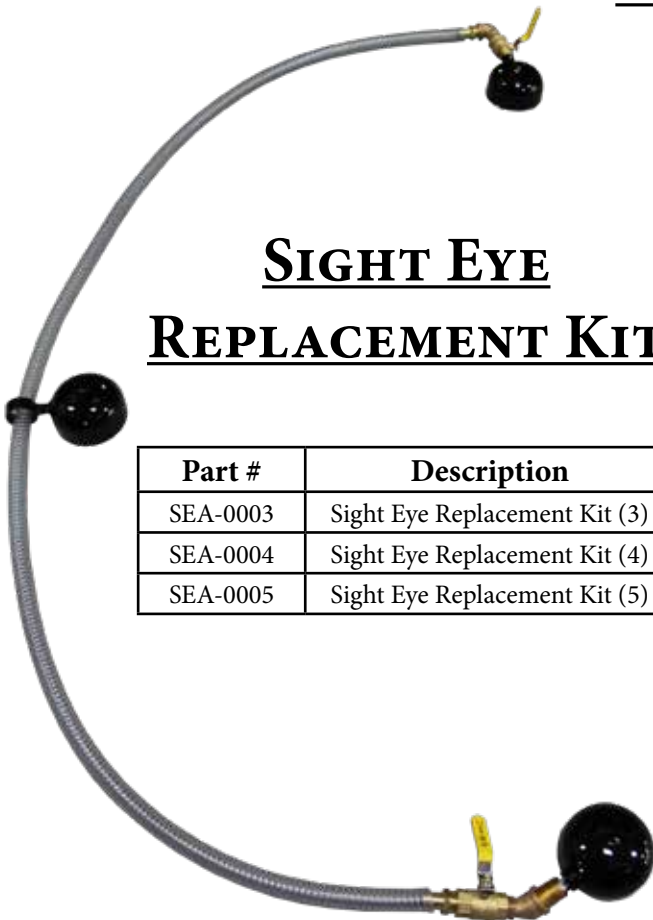

Features Include:

- Steel, Aluminum Or Stainless Steel Design
- Extra Thick Weldable Base
- Removable Glass or Plastic Lens
- O-Ring Style Seal
- High Impact Plastic Hand Wheel

Part #	Description
SEA-0003	Sight Eye Replacement Kit (3)
SEA-0004	Sight Eye Replacement Kit (4)
SEA-0005	Sight Eye Replacement Kit (5)

Part #	Description	Weight
SE-2	2" Plastic Sight Eye, Complete (70 PSI)	.5 lbs.
SE-3	3" Plastic Sight Eye, Complete (70 PSI)	1.25 lbs.
SE-5	5" Glass Sight Eye, Complete-Steel (70 PSI)	5 lbs.
SE-2GL	2" Glass & O-Ring	N/A
SE-3GL	3" Glass & O-Ring	N/A
SE-5GL	5" Sight Eye Glass Bowl	.5 lbs.
SE-5HW	5" Sight Eye Hand Wheel	.25 lbs.
SE-5PL	5" Sight Eye Plate	.29 lbs.
CPL-4-G	5" Sight Eye Gasket	.06 lbs.

LOAD LEVEL INDICATORS



Features Include:

- Internal O-Rings For Positive Shut Off
- Installation Requires No Welding
- External Grease Fittings for Easy Lubrication
- External Indicator Arrow

Part #	Description
LI-4	Stainless Level Indicator
VPA-NVE-4003190	Repair Kit
DL-0089	Decal Level Indicator

SEELVEE ANNIHILATOR

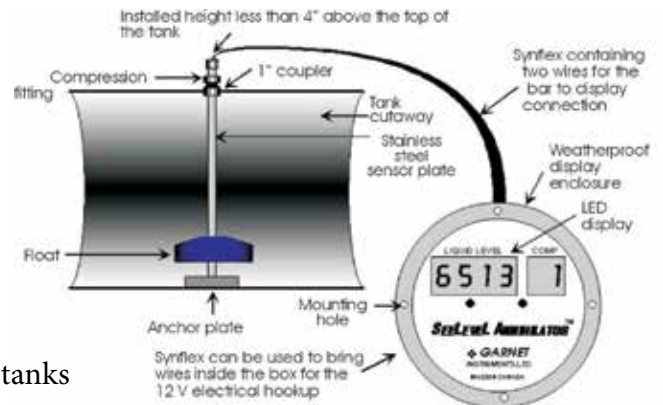

- Provides a product volume readout for truck tanks
- Provides reliable electronic solutions to:
 - Uncertainty of the amount of product being loaded or unloaded
 - Weigh scale fines by letting you know the exact amount of fluid in the tank
 - Pump damage due to water ingestion
- No moving parts except for the molded polyethylene float ensures high reliability
- LED display provides excellent nighttime visibility
- Multi-compartment ready, monitoring up to three different compartments
- Designed for products such as water, sewage or non-flammable chemicals

VACUUM PRESSURE GAUGES



- Heavy Duty Clear Lens
- Large 4" or 2 1/2" Dial On Liquid Filled Gauges
- 1/4" Male NPT Bottom Fitting
- 0-30" Vacuum and 0-30 PSI

Part #	Description	Weight
VPG-250-4L	2 1/2" Liquid Filled Vacuum Pressure Gauge, (0-30 PSI)	1 lb.
VPG-04-4L	4" Liquid Filled Vacuum Pressure Gauge, (0-30 PSI)	2 lbs.

VACUUM / PRESSURE SNUBBER

Increase Gauge Life!



Part #	Description
SN-0404-150B	Pressure / Vacuum Snubber



TRUCK LIGHTS

Position	Part #	Description
1	EL-1247	Amber Marker Light LED 2.5"
2	EL-1297	Amber Side Marker / Aux. / Turn
3	EL-1246	Red Marker Light LED 2.5"
4	EL-1249-01	Red / Stop / Tail / Turn LED 4"
5	EL-1261	Clear Back Up Light, LED
5	EL-1294	Clear Back Up Light
6	EL-1241	Strobe Light Quad Flash
7	EL-1233	Auxillary Work Light Clear
8	EL-1248	Upper ID Red Low Pro 2"
9	EL-1295	License Plate Lamp LED



HEATED VALVE JACKETS

Our heated valve jackets protect the valve from freezing in cold weather by circulating engine coolant through a jacket in front of a valve on any truck. Easy to install, TTMA flanges allow for universal mounting.

Part #	Description
HVJ-03TT	Heated Valve Jacket, Steel 3"
HVJ-03TT-SS	Heated Valve Jacket, Stainless 3"
HVJ-04TT	Heated Valve Jacket, Steel 4"
HVJ-04TT-SS	Heated Valve Jacket, Stainless 4"
HVJ-06TT	Heated Valve Jacket, Steel 6"
HVJ-06TT-SS	Heated Valve Jacket, Stainless 6"

ELECTRIC HOT BLOCKS

Part #	Description
HVJ-E3L	Electric Heated Valve Block, 3" Lever Valve
HVJ-E3B	Electric Heated Valve Block, 3" Butterfly Valve
HVJ-E4L	Electric Heated Valve Block, 4" Lever Valve
HVJ-E4B	Electric Heated Valve Block, 4" & 6" Butterfly Valve
HVJ-E4B-B	Insulated Blanket for 4" Valve
HVJ-E6L	Electric Heated Valve Block, 6" Lever Valve
HVJ-E6B-B	Insulated Blanket for 6" Valve





CUSTOM TOOLBOXES

Allows you to store, haul and secure all the tools and accessories you need!

- Available in aluminum or steel
- Choice of polished or diamond plate doors
- Single or double configurations



Call today for size, pricing and availability!

BACK-UP CAMERAS



- Increase safety
- Decrease the chance of pulling away while your truck is still hooked up
- Avoid damage to your truck
- Allows you to back your truck out of the tightest spot with ease

Part Number : EL-1347



GROUNDING REELS

Part Number : HR-GR75-50

- These reels bond and/or ground aircraft, fuel trucks and other equipment.
- Provide smooth operation and require minimum cable pull
- Declutching arbor and adjustable guide arm with cable guide
- Standard finish is oven-cured enamel



SAFETY LOCKS



A locking mechanism for camlock fittings

Size	Part #
3"	CPL-3-SL
4"	CPL-4-SL

SAFETY BUMPERS



- Protects fittings from damage
- Replaces traditional quick connect caps and plugs
- Provides a comfortable handle

Part #	Description
CPL-3-SBS	3" Safety Bumper Set
CPL-4-SBS	4" Safety Bumper Set



BUILT TO WORK THE WAY YOU WORK!

Keep your trucks on the road and on the job with help from the knowledgeable, friendly staff at Pik Rite. Our dedicated parts department makes maintaining your vacuum tanker easy. We deliver a wide array of stock and custom parts from a variety of high-quality manufacturers.

We also design and fabricate specialty parts to your individual specifications right here in our shop.

Every month, our parts department offers special discounts on select products.

DON'T MISS ANOTHER MONTH OF SAVINGS!

Sign up for email alerts at: www.pikrite.com/parts-special

Or call 800-326-9763 to talk to one of our parts experts today!
Hours: Monday through Friday, 8 AM to 5 PM, Eastern Time Zone



60 PIK RITE LANE, LEWISBURG, PA 17837